

Nidec

All for dreams

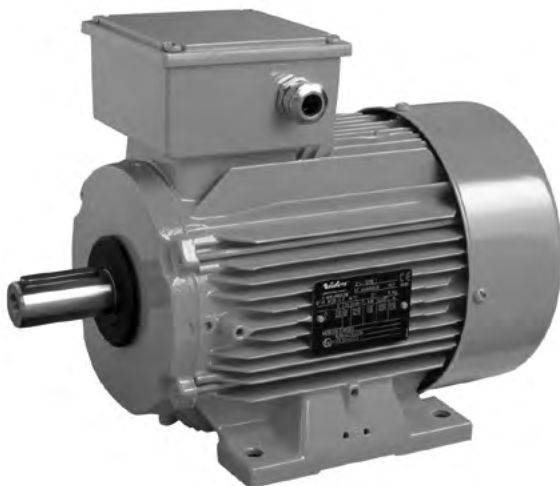

*Commissioning and
maintenance guide*



LSN - FLSN
Ex ec IIC T3 Gc

*Three-phase asynchronous
motors for explosive gas
and dust atmospheres*

Reference: 5724 en - 2019.10 / a

LEROY-SOMERTM

GENERAL WARNING

These symbols   appear in this document whenever it is important to take special precautions during installation, operation, maintenance or servicing of the motors.

It is essential that electric motors are installed by experienced, qualified and authorized personnel.

In accordance with the main requirements of EC Directives, the safety of people, animals and property should be ensured when fitting the motors into machines.

Particular attention should be given to equipotential ground or earthing connections.

The noise levels of the machines, measured under standard conditions, complies with the requirements of the standard and does not exceed the maximum value of 85 dB(A) pressure at 1 metre.



The following precautions must be taken before working on any stationary device:

- **AC voltage disconnected and no residual voltage present**
- **Careful examination of the causes of the stoppage (jammed transmission - loss of phase - cut-out due to thermal protection - lack of lubrication, etc.)**



Electric motors are industrial products. They must therefore be installed by qualified, experienced and authorized personnel. The safety of people, animals and property must be ensured when fitting the motors into machines (please refer to current standards).

Personnel likely to intervene on electrical installations and equipment in explosion risk areas shall be trained and authorized specifically for this type of equipment.

Indeed, knowledge is required about the risks specific to electricity, but also those due to chemical properties and physical characteristics of the products used in the installation (gas, vapours, dusts), as well as the environment in which the equipment operates. These elements condition the risks of fire and explosion.

More particularly, he/she must be informed and aware of the reasons for particular safety instructions in order to observe them. For example:

- never open when live,
- do not open when live if a dusty explosive atmosphere is present,
- do not repair in live conditions,
- do not manoeuvre under load,
- wait a few minutes before opening,
- refit the gaskets to guarantee sealing.



Before commissioning, check that the information shown on the nameplate is compatible with the explosive atmosphere that is present and with the zone where used.

NOTE:

LEROY-SOMER reserves the right to modify the characteristics of its products at any time in order to incorporate the latest technological developments. The information contained in this document is therefore liable to be changed without notice.

Copyright 2019: LEROY-SOMER MOTORS

This document is the property of Leroy-Somer.

It may not be reproduced in any form without prior authorization.

All brands and models have been registered and patents applied for.

Dear Customer,

You have just acquired a **LEROY SOMER safety motor**.

These motors benefit from the experience of one of the largest manufacturers in the world, using state-of-the-art technologies – automation, specially selected materials and rigorous quality control. As a result, the regulatory authorities have awarded our motor factories ISO 9001, Edition 2015 international certification.

We thank you for making this choice, and would ask you to read the contents of this manual.

By observing a few essential rules, you will ensure problem-free operation for many years.

LEROY-SOMER MOTORS



EU DECLARATION OF CONFORMITY OF USE AND OF INTEGRATION

	PS6 - DOCUMENT MANAGEMENT	Classification / File : S4T005
	EU DECLARATION OF CONFORMITY AND INCORPORATION <small>Revisión : E Date : 2019/09/25 Page : 2 / 2</small> <small>Annule et remplace / Cancels and replaces D du / from 2017/12/15</small>	<small>Doc type : S4T005 Rev B du from 26/11/2014</small>

We, **MOTEURS LEROY SOMER, Bd - Marcellin LEROY 16915 Angoulême cedex 9 France**, declare, under our own responsibility, that the following products :

LSN and FLSN series type "Ex ec" increased safety induction motors

bearing the following markings on their nameplates:

CE  Ex ec IIC T3 (or T4) Gc (zone 2)
or CE  Ex ec IIC T3 (or T4) Gc Ex tc IIC T125°C Dc (zone 2 and 22)

IIC motors can be marked IIA or IIB for commercial reasons.

Comply with :

European Directives:

- Low Voltage Directive 2014/35/EU
- ROHS 2 Directive 2011/65/EU
- Electromagnetic Compatibility Directive 2014/30/EU
- ATEX Directives: 2014/34/EU

European and international standards:

EN 50581 :2012; 60034-1:2010; 60034-7:1993/A1:2001; EN 60034-9:2005/A1:2007; 60034-14:2018; 60034-30-2:2016; EN 62262 :2002; IEC 60079-0:2011; EN 60079-0:2012/A11 :2013; IEC 60079-7:2015; EN 60079-7:2015; IEC 60079-31:2013; EN 60079-31:2014 (Ex tc)



This conformity permits the use of these ranges of products in machines subject to the application of the Machinery Directive 2006/42/EC, provided that they are integrated or incorporated and/or assembled in accordance with, amongst others, the regulations of standard EN 60204(All parts) "Electrical Equipment for Machinery".

The products defined above may not be put into service until the machines in which they are incorporated have been declared as complying with the applicable Directive.

Installation of these materials shall be done by a professional who is responsible to comply with the regulations, decrees, laws, orders, directives, application circulars, standards, rules or any other document relating to the installation site. He will be also responsible for the respect of values stamped on (motor) rating plate(s), instruction manual, installation instructions, maintenance manuals and/or any other document supplied by the manufacturer. **MOTEURS LEROY-SOMER accepts no liability in the event of failure to comply with these rules and regulations.**

Signature of plant quality manager : G.GARDAIS date: 2019 september the 25th

Signature of plant technical manager : B.VINCENT date: 2019 september the 25th

 Consulter le système de gestion documentaire afin de vérifier la dernière version de ce document.
For the latest version of this document, please access the document management system.

	Process: POC2 New product development control	no. 0 0 1 1 T 5 0 0
	EU DECLARATION OF CONFORMITY AND OF INCORPORATION FLSN and FLSES motors <small>Rev. A of 10/04/2019 Page 1 / 1</small> <small>Genève and release</small>	<small>Doc type : POC2 Rev A du from 10/04/2019</small>

We, **Constructions Electriques de Beaurourt (CEB), 14, rue de Nampiere, 91050 BEAUCOURT, France**, (a company of the **Nidec / Leroy-Somer holding SA** group, boulevard Marcellin Leroy, CS 10015, 16915 ANGOULEME cedex 9, France) declare, under our sole responsibility that the following products:

FLSN type induction motors ("ec" protection mode) and FLSES type induction motors ("tc" protection mode)

(bearing the following marking(s) on their nameplates:

CE  Ex ec IIC T3 Gc or (T4 Gc or T5 Gc or T6 Gc) for zone 2
or CE  Ex ec eb IIC T3 Gc or (T4 Gc or T5 Gc or T6 Gc) for zone 2 if "eb" junction box
or CE  Ex tc IIB T125°C Dc IP 55 or Ex tc IIC T125°C Dc IP 65 (up to 200°C) for zone 2 and 22
+ H 3 D
or CE  Ex ec eb IIC T3 Gc or (T4 Gc or T5 Gc or T6 Gc)
or CE  Ex tc IIB T125°C Dc IP 55 or Ex tc IIC T125°C Dc IP 65 (up to 200°C) for zone 2 and 22 if "eb" junction box
+ H 3 D
or CE  Ex tc IIB T125°C Dc IP 55 or Ex tc IIB T125°C Dc IP 65 (up to 200°C) for zone 22

comply with the following European Directives:

- Low voltage: 2014/35/EU
- RoHS 2: 2011/65/EU
- Electromagnetic Compatibility: 2014/30/EU
- EPT: 2009/125/EC and its (EC) implementation regulation: 640/2009 and amendments (for the products certified) 2014/34/EU
- ATEX: 2014/34/EU
- European standards: EN 50581:2012; EN 60034-1:2010; 60034-7:1993/A1:2001; 60034-9:2005/A1: 2007; 60034-14:2018; 60072-1:1991; 62262:2004; EN 60079-0: 2012/A11:2013; 60079-7:2015; 60079-31:2014; 60529:2014; 62262:2004
- International standards: IEC 50581:2013; IEC 60034-1:2017; 60034-7:1993/A1:2001; 60034-9:2005/A1:2007; 60034-14:2004/A1:2007; 60072-1:1991; 62262:2002; IEC 60079-0:2011/A11:2013; 60079-7:2015; 60079-31:2013; 60529:2015
- and with the types awarded:
 - type examination certificate: IERIS 18ATEX0011 X
 - certificate of conformity: IECX INE 19.0015X

issued by the Notified Body: IERIS (0080) – BP2 – Parc technologique ALATA 60550 VERNEUIL-EN-MALATTE

This compliance permits the use of these ranges of products in a machine subject to the application of the machinery directive 2006/42/EC, provided that they are integrated or incorporated and/or assembled in accordance with, amongst others, the rules of standard EN 60204 (all sections) "Electrical Equipment of Machines".

This equipment must be installed by a professional, liable for ensuring compliance with all installation rules, decrees, orders, laws, directives, application memos, standards (IEC-EN 60079-14, etc.), regulations, good trade practices and any other document on the installation site. The professional is also liable for ensuring compliance with the values indicated on the motor information plate(s), instruction manuals, installation and maintenance manuals and any other document provided by the manufacturer.

Constructions Electriques de Beaurourt (CEB) cannot be held liable for non-compliance with all or part of the above.

Date and signature of the Technical Department: 18th July 2019 

 Consulter le système de gestion documentaire afin de vérifier la dernière version de ce document.
For the latest version of this document, please access the document management system.

CONTENTS

INDEX

1 - RECEPTION	5
1.1 - Identification and marking	5
2 - STORAGE	6
3 - COMMISSIONING	6
3.1 - Protocol for lubrication during commissioning	6
3.2 - Checking the insulation	7
4 - INSTALLATION	7
4.1 - Position of the lifting rings	7
4.2 - Location - ventilation	8
4.3 - Preparation of the fixing support	9
4.4 - Coupling	9
4.5 - Important information to be taken into consideration during installation	9
5 - ELECTRICAL PARAMETERS - LIMITING VALUES	10
5.1 - Limitation of disturbances caused by starting of motors	10
5.2 - Supply voltage	10
5.3 - Starting time	10
5.4 - Supply with frequency inverter	10
6 - USE	11
7 - SPECIAL OPERATING CONDITIONS	12
7.1 - Variable speed use	13
8 - ADJUSTMENT	16
9 - MAINS CONNECTION	18
9.1 - Terminal box	18
9.2 - Connection to the electrical supply	18
9.3 - Terminal block or isolator connection wiring diagram	19
9.4 - Direction of rotation	19
9.5 - Earth terminal and earthing	19
9.6 - Connecting the power supply cables to the terminal block	20
9.7 - Indication of cable gland size and type for 400V rated supply voltage if drillings required without details of hole diameters being given	22
9.8 - Admissible number and maximum size of holes for cable glands per "eb" terminal block	23
9.9 - Recommended cable temperatures	23
10 - MAINTENANCE	24
10.1 - General	24
10.2 - Corrective maintenance: general	25
10.3 - Safety rules	26
10.4 - Routine maintenance	26
10.5 - Bearing housing maintenance	27
10.6 - IP Leak tightness of motor	29
10.7 - Groups IIC & III paints	29
10.8 - Troubleshooting guide	30
10.9 - Preventative maintenance	31
10.10 - Recycling	31
11 - LSN MOTORS REMOVAL AND REFITTING PROCEDURE	32
11.1 - LSN 80 to LSN 160MP/LR and FLSN 80 to 132 motors	32
11.2 - LSN 160M/L, LSN 180MT/LR motors	34
11.3 - LSN 180L, LSN 200, LSN 225ST/MT/MR, LSN 250MZ motors	36
11.4 - LSN 250ME, LSN 280SC/MC motors	38
11.5 - LSN 280SD/MD, LSN 315 motors	40
12 - LSN MOTORS REMOVAL AND REFITTING PROCEDURE	42
12.1 - FLSN 160 and 180 motors	42
12.2 - FLSN 200 to 225ST motors	44
12.3 - FLSN 225 to 280 motors	46
12.4 - FLSN 315S to 355LD motors	48
12.5 - FLSN 355LK to 450 motors	50

Acceptance	5
Adjustments	16
Alarm - early warning	11
Assembly	6
Balancing	9
Bearing housing fixing rods or screws: tightening	25
Bearing housings	26 - 27
Belts	17
Built-in thermal protection	11
Cable gland	18
Cables	20
Capacitors	24
Connection to mains	18 - 20
Connection wiring diagrams	19
Connection	20
Corrective maintenance	25
Coupling	9
Coupling sleeves	16
Digstart	12
Direction of rotation	19
Draining off condensation water	26
Earth terminal	19
Earth	12 - 19
Europe Directives	3 - 5
Fan	8
Frequency inverter	13
Handling	7 - 8 - 9
Heaters	11
Identification	5
Inertia flywheel	16
Insulation	7
Lifting ring	7
Location	8
Lubrication - Grease nipples	6 - 24 - 25 - 26
Lubrication	25 - 26
Nameplate	5
Power supply	10 - 20
Power	10
Protections	11
Pulleys	17
Routine maintenance	26
Spare parts	24
Starting	10
Storage	6
Terminal box	18
Terminal plate: tightening of nuts	20
Tolerances	16
Troubleshooting	30

1 - RECEPTION

This manual or its condensed version is to be given to the end user. In the event of this notice not being translated into the language of the country in which the motor is used, the distributor is responsible for its translation and for distributing it to end users.

Products to which this manual applies may not be commissioned before the machinery in which they are installed has been declared to conform to the Directives that apply to it.

This equipment and its accessories or associated equipment must be installed by a professional, who is liable for ensuring compliance with all installation rules, decrees, orders, laws, directives, application memos, standards (where explosive atmospheres are involved, standard IEC-EN 60079-14 as a minimum), regulations, good trade practices and any other documents relating to the installation site. The professional is also liable for ensuring compliance with the values indicated on the motor information plate(s), instruction manuals, installation and maintenance manuals and any other document provided by the manufacturer.

Constructions Electriques de Beaucourt (CEB) and LEROY-SOMER cannot be held liable for non-compliance with all or part of the above or with any part of this manual.

On receipt of your motor, check that it has not suffered any damage in transit.

If there are obvious signs of damage, contact the carrier (you may be able to claim on their insurance) and after a visual check, turn the motor by hand to detect any malfunction.

1.1 - Identification and marking

Check that the information shown on the nameplate is compatible with the explosive atmosphere that is present, the utilisation zone and the ambient and surface temperatures.

Mains supply nameplate

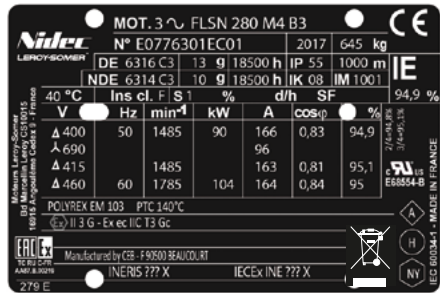

Variable speed nameplate

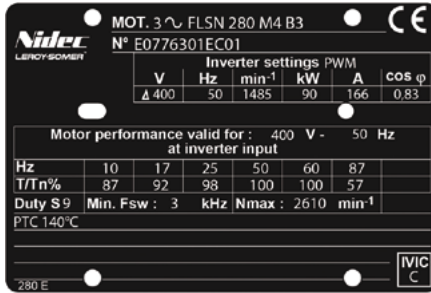

Quadratic torque variable speed nameplate

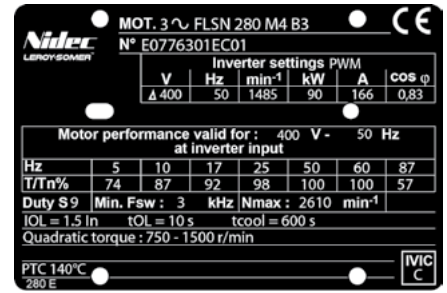

Definition of symbols used on nameplates:

Legal mark of equipment compliance with the requirements of European Directives.

Special ATEX marking IECEx

- : Equipment group "dust" (if tc)
- IIG, or, II 3G and II 3D : ATEX/IECEx marking
- Ex ec : "spark-free envelope" protection mode
- IIC : Equipment group "gas"
- T3 : Temperature class "gas"
- Gc : EPL level "gas"
- Ex tc : Protection mode "dust" (option)

Zone	ATEX/IECEx marking	Gas protection mode marking	Dust protection mode marking (if tc)	Index of protection min
2	II 3 G	Ex ec IIC T3 Gc	/	IP 55
2 & 22	II 3 D	Ex ec IIC T3 Gc	Ex tc IIIC T125°C Dc	IP 55

- IIIC : Equipment group "dust" (if tc)
- T125°C : Maximum surface temperature (if tc)
- Dc : "dust" EPL level
- INERIS ... X : ATEX attestation number
- IECEx INE... : IECEx certificate no.

Motor symbols:

- MOT 3 ~ : Three-phase A.C. motor
- FLSN : Motor type
- 280 : Frame size
- M : Housing symbol
- 4 : 4 poles

- B3 : Operating position
- No. : Serial number
- 2017 : Year of manufacture
- IM : Operating position symbol
- °C : Maximum ambient temperature
- Ins. cl. : Winding insulation class
- S : Standard operating duty
- % : Operating duty
- d/h : Number of starts per hour
- SF : Duty factor

- kg : Weight
- DE : Drive end bearing
- NDE : Non drive end bearing
- g : Quantity of grease to be added per bearing at each re-lubrication (in g)
- h : Interval in hours between re-lubrication
- IP : Index of protection
- IK : Impact resistance index
- m : Maximum operating altitude
- V : Supply voltage
- Hz : Supply frequency
- min⁻¹ : Rated speed of rotation
- kW : Rated power
- A : Rated current
- cos φ : Power factor
- % : Efficiency at 4/4 load
- Δ : Delta coupling
- λ : Star coupling

- POLYREX EM 103 : Grease part number for bearings
- Insulated bearing : NDE : Insulated bearing NDE side
- Manufactured by CEB : Equipment manufacturer
- EAC Ex : Equipment for explosive atmospheres certified for Eurasia
- cURus : Insulation system class homologated for USA and Canada
- : Vibration level code
- : Balancing mode code
- : Starting requirements code
- 279 E : Plate reference

- IE % : Efficiency level and efficiency, at rated load and voltage
- 2/4 : Efficiency at 2/4 load
- 3/4 : Efficiency at 3/4 load

Inverter settings PWM : Characteristics for setting the PWM drive to allow temperature class of motor to be met
 Motor performance valid for 400V - 50Hz at inverter input : Motor performance for a voltage of 400V - 50 Hz at the drive input

- Duty S9 : Performances given for S9 duty
- Min.Fsw : Minimum switching frequency of the drive in kHz
- Nmax : Admissible maximum motor speed in rpm
- PTC 140°C : PTC sensor type - temperature limit = 140°C
- IOL : Admissible over-current = 1.5 x rated current
- tOL : Maximum period during which over-current can occur (in secs)
- tcOOL : Minimum duration during which the motor must be at the max of its rated current between 2 over-current events (in secs)
- Quadratic torque : Type of torque: quadratic
- IVIC : Pulse voltage insulation class code

2 - STORAGE

Prior to commissioning, motors should be stored:

- in a dry location, in their original packaging and protected from moisture: for relative humidities in excess of 90% the insulation may fall off very rapidly and around 100% may be practically zero. Monitor the condition of the rust prevention protection of unpainted parts. Storage conditions can be between -40°C and +80°C. For storage in an environment at between -40°C and -20°C: avoid impacts with the motor (damage due to the impact resistance of the equipment at these temperatures).

For very long period storage the motor may be packaged in a sealed envelope (e.g. thermo-welded plastic) with desiccator packs inside:

- protected from large and frequent temperature variations in order to prevent condensation. During the storage periods only drain plugs should be removed to eliminate condensation water.

- if the area is subject to vibration, try to reduce the effect of this vibration by placing the motor on a damping support (rubber plate or similar).

- turn the rotor a fraction of a turn once a fortnight to prevent the bearing rings from becoming marked.

- do not remove the rotor locking device (if there are roller bearings).

Even if the motor has been stored in the correct conditions, certain checks must be carried out before it is started up:

Greasing

- Motors equipped with permanently greased bearings:

Maximum storage period: 2 years. After this time, replace the bearings.

- Motors equipped with bearings that can be re-greased:

Storage period	Less than 2 years	The motor may be commissioned if the recommendations indicated in § 3 are followed to the letter.
	More than 2 years	Bearings must be replaced and bearing housings (or flanges) must be cleaned and degreased in order to renew the grease entirely, in accordance with the information shown on the nameplate (quantity and type of grease). Replace shaft passage seals and for IP66 motors recess seals before starting.

Greases used by LEROY-SOMER:

See nameplates.



Warning! Do not carry out the high voltage test on auxiliaries.



In the event of the machine being re-painted, the thickness of the coat must not exceed 2 mm and 0.2 mm for IIC group equipment. Otherwise it must be anti-static irrespective of its thickness if the motor is II 3G and II 3D.

3 - COMMISSIONING

Before starting users are responsible for checking that the equipment, the gas (and if relevant dust) group and conditions of use are compatible.

In all cases, compatibility of the motor and its environment must be guaranteed before its installation and also throughout its life.



Electric motors are industrial products. THEY must therefore be installed by qualified, experienced and authorized personnel. The safety of people, animals and property must be ensured when fitting the motors into machines (please refer to current standards).

3.1 - Protocol for lubrication during commissioning

Given the “pot” storage lives stated by oil companies and the transport and storage conditions, the rotation systems of all motors must be subject to enhanced monitoring during the first week of operation.

The aim of this monitoring is to ensure that an oil film is formed on the bearing tracks, thus ensuring optimum operation of the rotation system. Finally, this means that on the one hand personnel can become familiar with the operation of the equipment and on the other hand allows any teething troubles associated with the installation to be identified.

The amount of grease indicated for re-greasing on the nameplate must be added when topping-up with grease.

Greases must not be mixed. Grease used for top-ups must be that stated on the nameplate.

If mixed accidentally, bearing housings (or flanges) must be removed and fully cleaned and degreased, and the bearings must be changed.

In specific terms, the operations to be carried out during installation are as follows:

- Before installing the motor, top-up with grease and rotate the motor by hand for ten or so turns.
- After starting the motor (10 min), top up with grease.
- After 24 hours continuous operation, top up with grease.
- After an operating period of 100 to 200 hours, top up with grease.
- During this starting period (up to 50 hours operation after the last top up) there must be intensive monitoring. The bearing housing temperatures and vibration must be measured frequently.

This data is to be retained by operators. It represents a database and history which will be useful for future maintenance.

3.2 - Checking the insulation

Throughout the period required for checking insulation, ensure that there is no explosive atmosphere present.

⚠ Before operating the motor we recommend checking the insulation between phases and earth and between phases.

Motors are factory-fitted with preventative advice labels which must kept legible.

Before commissioning remove condensation (see §10.4 - ROUTINE MAINTENANCE)

This check is essential if the motor has been stored for longer than 6 months or if it has been kept in a damp atmosphere. This measurement must be carried out using a megohmmeter at 500 volts DC (do not use a magneto-electric system). It is better to carry out an initial test at 30 or 50 volts and if the insulation is greater than 1 megohm, carry out a second test at 500 volts DC for 60 seconds. The insulation value must be at least 10 megohms in cold state.

If this value cannot be achieved, or routinely if the motor might have been splashed with water or salt spray, or kept for a long period in a very humid place, or if it is covered with condensation, it is recommended that the stator be dried for 24 hours in an oven at a temperature of 110 °C to 120 °C.

If it is not possible to dry the motor in an oven:

- supply the motor, with the rotor immobilised, with a three-phase AC voltage which is 10% below the rated voltage, for 12 hours (use an induction regulator or a step-down transformer with adjustable points).

- or supply it with DC supply with the 3 phases in series, with a voltage value of 1 to 2% of the rated voltage (use a separate excitation DC generator or batteries for motors of less than 22 kW).

- NB: The AC current must be monitored using a clamp-on ammeter, DC using a shunt ammeter. This current must not exceed 60 % of the rated current.

It is recommended that a thermometer be fitted to the motor frame: if the temperature exceeds 70 °C, reduce the indicated voltage or current by 5 % of the original value for every 10 °C difference.

While it is drying, all the motor orifices must be open (terminal box, drain holes). Before starting replace all plugs so that the motor exhibits the plated degree of protection. Clean the orifices and plugs before refitting them.

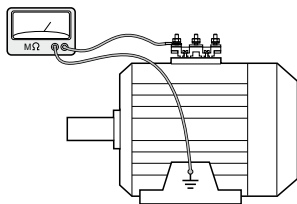

⚠ Warning! Since the high voltage test was carried out at the factory before dispatch. If it needs to be repeated, this should be performed at half the standard voltage, i.e.: 1/2 (2U+1000V). Check that the capacitive effect resulting from the high voltage test is eliminated before connecting the terminals to ground.

⚠ For all motors before commissioning:
 - remove the dust from the entire machine
 - rotate the motor at no load (no mechanical load) for 2 to 5 minutes, checking that there is no abnormal noise. If there is any abnormal noise, see section 10.

4 - INSTALLATION

4.1 - Position of the lifting rings

⚠ The lifting rings are provided for lifting only the motor. They must not be used to lift the machine after the motor has been fitted to it.

Labour regulations stipulate that all loads over 25 kg must be fitted with lifting devices to facilitate handling.

The overall mass of motors can vary according to their power, their mounting position and whether the motors are fitted with optional equipment. The actual weight of each Leroy-Somer motor is indicated on its nameplate. The positions of the lifting rings and the minimum dimensions of the loading bars are given below in order to help with preparation for handling the motors. If these precautions are not followed, there is a risk of warping or crushing some equipment such as the terminal box, protective cover or drip cover.

• Horizontal position

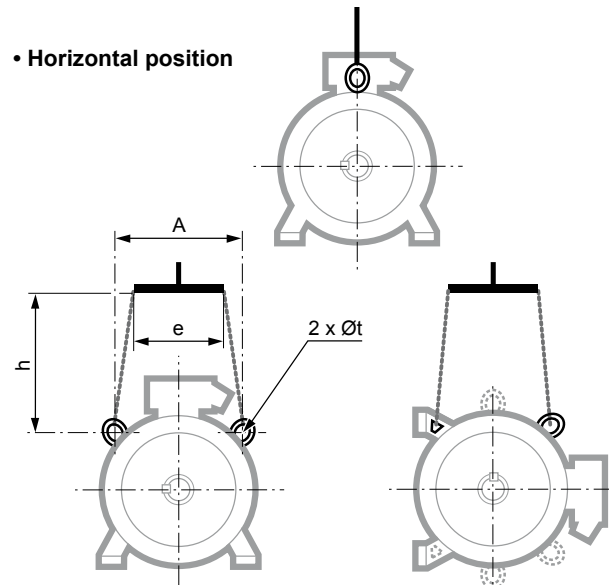

Type	Horizontal position			
	A	e min	h min	Øt
100	120	200	150	9
112	120	200	150	9
132	160	200	150	9
160	200	160	110	14
180 MR	200	160	110	14
180 L	200	260	150	14
200	270	260	165	14
225 ST/MT	270	260	150	14
225 M	360	265	200	30
250	360	380	200	30
280	360	380	500	30
315 S	310	380	500	17
315 M/L	360	380	500	23
355	310	380	500	23
355 LK - 400	735	710	500	30
400 LK - 450	730	710	500	30

⚠ Motors intended for use in the vertical position may be delivered on pallets in a horizontal position. When the motor is pivoted, the shaft must under no circumstances touch the ground as the bearings could be irreparably damaged.

• Vertical position

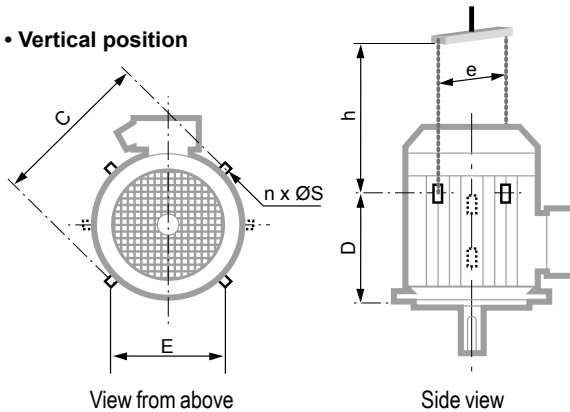

Type	Vertical position						
	C	E	D	N	ØS	e min*	h min
160	320	200	230	2	14	320	350
180 MR	320	200	230	2	14	320	270
180 L	390	265	290	2	14	390	320
200	410	300	295	2	14	410	450
225 ST/MT	410	300	295	2	14	410	450
225 M	480	360	405	4	30	540	350
250	480	360	405	4	30	540	350
280 S	480	360	485	4	30	590	550
280 M	480	360	585	4	30	590	550
315 S	590	-	590	2	17	630	550
315 M/L	695	-	765	2	24	695	550
355	755	-	835	2	24	755	550
355 LK - 400	810	350	1135	4	30	810	600
400 LK - 450	960	400	1170	4	30	960	750

* If the motor is fitted with a drip cover, allow an additional 50 to 100 mm to avoid damaging it when the load is swung.

4.2 - Location - ventilation

Our motors are cooled in accordance with method IC 411 (standard IEC 60034-6) i.e. "machine cooled by its surface, using the ambient fluid (air) flowing along the machine".

The fan at the non-drive end cools the motor. Air is sucked in through the grille of a fan cover (which provides protection against the risk of direct contact with the fan in accordance with standard IEC 60034-5) and blown along the housing fins to ensure thermal equilibrium of the motor whatever the direction of rotation.

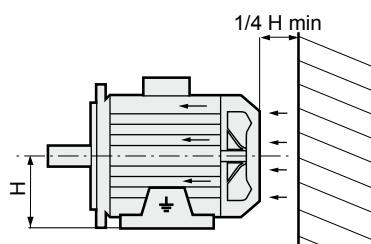

The motor is to be installed in an adequately ventilated area, where the air inlets and exits are free by a value of at least a quarter of the frame height.

Check that the fan cover bears no impact marks.

Blocking (clogging) the cover grille and the housing fins, even accidentally, will adversely affect the operation of the motor and its safety.

With vertical operation with shaft extension downwards, it is recommended that the motor be equipped with a drip cover to prevent the entry of any foreign matter.

It is necessary to check that the hot air is not being recycled. If it is, pipes must be provided for the intake of cold air and expulsion of hot air, in order to prevent abnormal motor temperature rise.

In this case, if the air is not circulated by an auxiliary fan, the dimensions of the pipes must be such that the pressure losses are negligible compared to those of the motor.

Installation

Possibility of additional external heat

The motor temperature class does not take additional external heat into account (e.g. pump circulating a hot fluid).

The motor must be mounted in the position specified on the order, on a base which is rigid enough to prevent distortion and vibration.

Where the motor feet have six fixing holes, it is preferable to use those which correspond to the standard dimensions for the motor power rating (refer to the asynchronous motors technical catalogue) or failing this to those shown at B2.

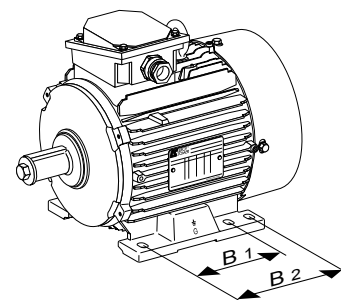

Provide easy access to the terminal box, the condensation drain plugs and, if appropriate, to the grease nipples.

Use lifting equipment which is compatible with the weight of the motor (indicated on the nameplate).

⚠ When the motor is fitted with lifting rings, they are solely for lifting the motor and must not be used to lift the whole machine after the motor has been fitted to it.

Note 1: When installing a suspended motor, it is essential to provide protection in case the fixing breaks.

Note 2: Never stand on the motor.

4.3 - Preparation of the fixing support

Installers must pay particular attention to ensuring good preparation of the motor fixing support.

Specific points to be observed:

- All metal supports must have undergone anti-corrosion treatment.
- The design and the dimensions of the support must prevent any vibration being transmitted to the motor, as well as any vibration caused by resonance.
- The support must be level and sufficiently rigid to enclose any short-circuit effects.
- The maximum level difference between the motor fixing feet must not exceed +/- 0.1 mm.

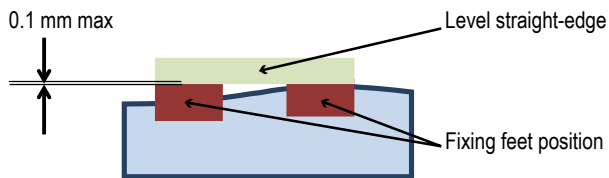

4.4 - Coupling

Preparation

Rotate the motor by hand to detect any possible fault due to handling.

Remove any protection from the shaft extension.

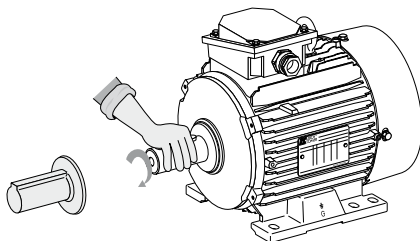

Drain off any condensation water that has formed inside the motor by removing the plugs from the drain holes. Before commissioning these plugs must be replaced and the motor must exhibit the plated degree of protection.

Rotor locking device

For made-to-order motors with roller bearings, remove the rotor locking device.

In exceptional circumstances when the motor has to be moved after the coupling device has been fitted, the rotor must be re-immobilized.

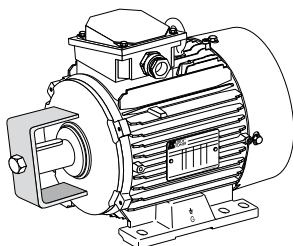

Balancing

Rotating machines are balanced in accordance with standard IEC 34-14:

- half-key when the shaft extension is marked H.

When specifically requested, balancing may be carried out:

- no key when the shaft extension is marked N,
 - full key when the shaft extension is marked F,
- any coupling element (pulley, coupling sleeve, slip-ring, etc.) must therefore be balanced accordingly.

Motor with 2 shaft extensions:

If the second shaft extension is not used, in order to conform to the balancing class the half-key or key must be firmly fitted in its groove so that it is not ejected during rotation (H or F balancing) and to protect it against direct contact.

4.5 - Important information to be taken into consideration during installation

- Equipment to which this manual applies may not be commissioned before the machinery in which it is installed has been declared to conform to the Directives that apply to it.

- When motors are supplied by suitable electronic converters and/or controlled by electronic command and control devices, they must be installed by a professional who will be responsible for ensuring compliance with the electromagnetic compatibility regulations for the country in which the product is installed.

- As standard the motors' impact resistance corresponds to "low" mechanical risk, therefore they must be installed in a low mechanical risk environment.

- All unused orifices must be blocked off using Ex threaded plugs.

- All accessories (cable glands, plugs etc.) cited in this notice must be of a type that is attested or certified for the group, the application (gas and/or dust) and the temperature class which correspond as a minimum to those for the location of the equipment (see the information on the nameplate). They are correctly tightened onto their support. A "KLINGERSILC-4400" fibre seal, for example, is placed between the cable glands, the plugs and their support. Cable glands must be appropriate for the supply cable and any auxiliary cables. The cables are correctly gripped in the cable glands.

Fitting must comply with the requirements of their instructions for use.

- The assembly of all these components must ensure the mode of protection (Ex) and the protection indices (IP, IK) specified on the nameplates.

- All threaded components must be fully tightened.

5 - ELECTRICAL PARAMETRES - LIMITING VALUES

5.1 - Limitation of disturbances caused by starting of motors

To ensure preservation of the installation, any significant overheating of pipework must be avoided whilst ensuring that the protective devices do not intervene during starting.

Disturbances resulting in the operation of other equipment connected to the same source are due to the voltage drop caused by the current demand on starting (multiple of the current passing through the motor at full load (about 7) see LEROY-SOMER asynchronous motors technical catalogue). Even though networks are increasingly capable of allowing direct starting, current demand must be reduced for certain installations.

Jerk-free operation and smooth starting mean that the driven machinery will be easier to use and have a longer operating life.

The two essential parameters for starting squirrel cage synchronous motors are:

- starting torque
- starting current.

The starting torque and the resistive torque determine the starting time.

Depending on the driven load, the torque and current can be altered to match the starting options of the machine and to match the supply options.

The five essential modes are:

- D.O.L. starting,
- star/delta starting,
- soft starting with autotransformer,
- soft starting with resistors,
- electronic starting.

Electronic starting modes control the voltage at the motor terminals throughout the entire starting phase, giving very gradual smooth starting.

5.2 - Supply voltage

The rated voltage is indicated on the nameplate.

5.3 - Starting times

Starting times must remain within the limits indicated below on condition that there are 6 or less starts during one hour. Three successive cold starts and two consecutive hot starts are allowed.

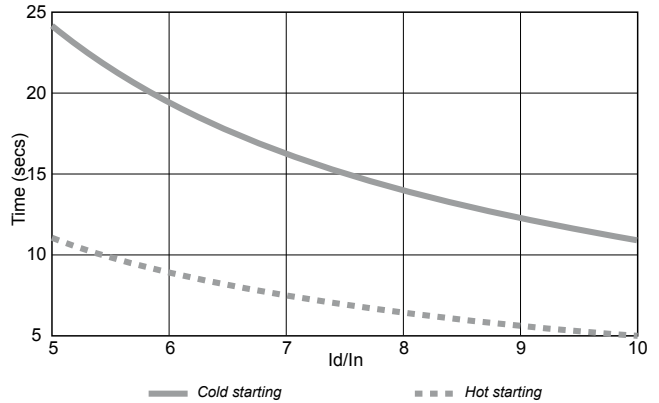

Permissible motor starting time as a function of the ratio I_D/I_N

In the event of frequent or difficult startup conditions, equip motors with thermal protection devices (see § 6 - USE).

5.4 - Supply with frequency inverter

See § 7.1.

5.5 - Operating duty

Leroy-Somer spark-free motors are certified for operating in S1, S2, S6 and S9 duty and in accordance with IEC/EN 60034-1.

As standard motors operating at variable speeds are plated as follows:

- * Mains supply plate: S1 duty.
- * Drive plate: S9 duty.

6 - USE

Thermal protection devices (see § 8) and heaters

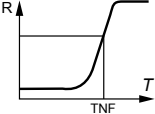
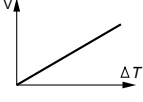
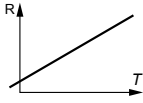
Type	Operating principle	Operating curve	Switch rating (A)	Protection provided	Mounting Number of devices*
Positive temperature coefficient thermistor PTC	non-linear variable resistor, indirectly heated 		0	general surveillance for transient overloads	Mounted with associated relay in control circuit 3 in series
Thermocouples T (T<150°C) Constantan Copper K (T<1000°C) Copper Copper-Nickel	Peltier effect		0	continuous surveillance of hot spots at regular intervals	Mounted in control panels with associated reading equipment (or recorder) 1 per hot spot
Platinum temperature sensor PT 100	Linear variable resistor indirectly heated		0	high precision continuous surveillance of key hot spots	Mounted in control panels with associated reading equipment (or recorder) 1 per hot spot

- NRT: nominal running temperature.

- The NRTs are chosen according to the position of the sensor in the motor and the temperature rise class.

* The number of devices relates to the winding protection.

Alarm and early warning

All protective equipment can be backed up by another type of protection (with different NRTs): the first device will then act as an early warning (light or sound signals given without shutting down the power circuits), and the second device will be the alarm (shutting down the power circuits).

Protection against condensation: space heaters

Marking: 1 red label

A glass fibre flexible resistor is fixed on 1 or 2 coil end turns. This resistor heats the machines when stopped and thus prevents condensation inside the machines.

Power supply: 230 V single-phase unless otherwise specified by the customer.

Recommended for use when ambient temperatures ≤ 20°C. In all cases the power dissipated must ensure that the temperature classification of the motor is observed.

Heaters or heating using the introduction of ac voltage must only be used when the motor is de-energised and cold.

The drain plugs at the bottom of the motor must be opened every six months or so. They must be refitted in place and the motor degree of protection guaranteed.

Thermo-magnetic protection

Motors are protected by the magneto-thermal device placed between the isolating switch and the motor. These protection devices provide total protection of the motor against non-transient overloads.

This device may be accompanied by fused circuit breakers.

Built-in indirect thermal protection

Motors may be equipped with thermal sensors as an option. These sensors follow the temperature changes at "hot spots":

- overload detection,
 - cooling check,
 - monitoring characteristic points for maintenance of the installation,
- guarantee of hot spot temperatures.

Thermal protection devices for (F)LSN motors must be connected to an "ic" minimum certified intrinsic safety barrier. If resistance variation, semi-conductor or thermocouple sensors are used, users must ensure that the safety circuit comprising probes, cables and actuators comply with the requirements of standard EN 50495.

The associated equipment must cause the motor to stop when the values of the thermal protection indicated below are reached (**see § Electrical characteristics of sensors and thermocouples below**).

 In order to ensure that the maximum temperature is never reached, thermal sensors inside the equipment, when these are mandatory, must be connected to a device (functionally independent and additional to any system which might be necessary for operation under normal conditions) which causes de-energisation of the motor when the thermal protection values below are reached.

 Under no circumstances can these sensors be used to carry out direct regulation of the motor operating cycles.

 Control and shut-off devices must be installed in panels located outside the hazardous zone or be of a recognised type.

Temperature sensor operating thresholds:

Temperature classes	Maximum value of the winding sensor and of adjustment of associated equipment		Maximum value of the bearing sensor and of adjustment of associated equipment	
	(F)LSN 80 to 250	(F)LSN 280 to 355	(F)LSN 80 to 250	(F)LSN 280 to 355
Frame size				
T6	100°C	100°C	80°C	70°C
T5	110°C	100°C	90°C	70°C
T4	150°C	130°C	120°C	80°C
T3	150°C	140°C	120°C	90°C
Maximum temperature of dust motor surface	Maximum value of the winding sensor and of adjustment of associated equipment		Maximum value of the bearing sensor and of adjustment of associated equipment	
Frame size	(F)LSN 80 to 250	(F)LSN 280 to 355	(F)LSN 80 to 250	(F)LSN 280 to 355
85°C	100°C	100°C	70°C	70°C
100°C	110°C	110°C	90°C	90°C
125°C	130°C	140°C	110°C	110°C
135°C	150°C	140°C	110°C	110°C
145°C	150°C	140°C	110°C	110°C

Electrical characteristics of sensors and thermocouples:

* I max = 5A.

* U max :

* for PT100 at 0°C = 2.5 V

* for PTC = 7.5 V

* for PTO/PTF = 7.5 V

* for thermocouple = 7.5 V

7 - SPECIAL OPERATING CONDITIONS

- Thermal protection (see § 6 & 9)

- Heaters (see § 6)

- Temperatures: storage and ambient

Note: T_a = ambient temperatures

If the motor has been stored at a temperature below -10°C , heat the motor (see § 3) and turn the shaft by hand before operating the machine.

If the motor is to be used at a temperature lower than -20°C , it may be fitted with heaters.

As standard construction, our motors are designed to operate at ambient temperatures T_a between -20°C and 40°C .

If $T_a < -25^{\circ}\text{C}$, shaft passage seals must be made of silicone and the fan must be metal. The terminal box gaskets must be made of silicone.

- Surface temperature

As standard, the maximum surface temperature at any point of the motor is 200°C as T3 with an ambient temperature $\leq 40^{\circ}\text{C}$.

If the motors are also used in dusty explosive surroundings, the maximum surface temperature is 125°C .

- Installation zones

Motors bearing equipment group III marking may be installed in dusty explosive atmospheres (zone 22).

- Connection

Particular attention must be paid to the information on the nameplate in order to choose the correct type of connection to the supply voltage.

Similarly the protection system and the supply cables (the voltage drop during the starting phase must be less than 3%) are to be selected according to the characteristics marked on the nameplate.

- Earthing

The motor must be earthed in accordance with the applicable regulations (protection of workers).

An external terminal on the frame is used for effective earth connection of equipotential links. This terminal must be prevented from working itself loose.

- Leak tightness

Monitor the condition of all seals and periodically replace them if necessary. At the shaft passages, take care not to damage the seals in contact with the keys and shoulders.

After removing drain plugs or ventilators where these are present, refit them in place in order to ensure the IP 55 or IP 65 degree of protection of the motor. Replace the seals that are removed using new seals with the same characteristics. Clean the orifices and plugs before refitting them.

Whenever removed and during preventative maintenance, replace seals (shaft passages, bearing housing recesses, terminal box cover etc.) using new seals with the same characteristics after cleaning the components. Shaft passage seals must be fitted using the same type of grease as the bearings.

- Employee safety

Protect all rotating devices before power-up.

If a motor is started up without a coupling device having been fitted, carefully immobilize the key in its housing.

All measures must be taken to provide protection against risks associated with rotation of components (sleeve, pulley, belts etc.).

Beware of backdriving when the motor is switched off. Appropriate precautions must be taken:

- pumps, install a non-return valve, for example.

- LEROY-SOMER “Digistart” electronic starter

This is micro-controlled multi-function electronic system, which is used with all squirrel-cage asynchronous three-phase motors.

It ensures smooth starting of the motor with:

- reduced starting current,

- smooth jerk-free acceleration achieved by controlling the current in the motor.

After starting, the DIGISTART carries out additional motor management functions in its other operating phases: steady state and slowing.

- Models from 18 to 1600 A

- Power supply: 220 to 700 V - 50/60 Hz

The DIGISTART is low-cost to install, and only an additional switch and fuses are required.

The “Digistart” electronic starter associated with the motor must be installed outside the hazardous zone.

- Contactors - Main switches

In all cases contactors, main switches etc. must be installed and connected in a panel outside the hazardous zone or be of a recognised type.

- Shock resistance

The motor can withstand a low mechanical impact (IK 08 according to EN 50102). The user must provide additional protection if there is a risk of significant mechanical shock.

- Fitting sensors or accessories

In the event that sensors (vibration sensors for example) or accessories (pulse generators for example) are fitted, these must be connected in a panel. All these accessories (as well as the panel if it not located outside the explosive atmosphere) must be of a type that is certified or attested for the group, the application (Gas or Gas and dust) and the temperature class which corresponds at least to that of the motor. Fitting must comply with the requirements of their instructions for use.

- Noise level

Most (F)LSN motors have an acoustic pressure level of less than 80 dB(A) (+/- 3dB) at 50Hz.

The values for each motor are given in our technical catalogue. When the motors operate using a drive, please contact us for the noise levels.

7.1 - Variable speed use

7.1.1 - General

Drive control by a frequency inverter can in fact result in an increase in the machine temperature rise, due to a significantly lower supply voltage than on the mains, additional losses related to the wave form produced by the drive (PWM) and the reduction in speed of the cooling fan.

Standard IEC 60034-17 describes numerous good practices for all types of electric motor, however since this is Leroy-Somers' area of specialist expertise, we describe the best ways to deal with variable speed in the section below.

The homologation conditions of our safety motors allow them to operate on frequency drives on condition that the required precautions are taken to ensure that under all circumstances there is compliance with the temperature class marked on the nameplate.

Drive control using a frequency inverter results in an increase in the machine temperature rise, primarily as the result of a reduction in cooling fan speed and a supply voltage which is significantly lower than that of the network. Consequently a reduction must generally be made in the rated power of the motor. Derating tables have been produced by our design bureau based on under-load tests on platforms, and on the requirements of IEC 60034-17. Depending on the application, on the desired speed range and the torque profile of the driven machine, Leroy-Somer will select the most suitable safety motor. The drive, if of a type not designed for operation in an explosive zone, must be located in a non-explosive zone.

In certain cases, the use of forced ventilation (where the fan is driven by an auxiliary motor whose type has been certified) may prove necessary. For small motors (frame height less than 160), the standard self-ventilated cooling mode (IC411) is nevertheless to be preferred.

A device for measuring the actual speed of the motor using an incremental or absolute encoder which is ATEX certified, may also be installed at the rear of most of our safety motors.

ATEX motors supplied through a frequency inverter are equipped with thermal protective devices in the winding. These must operate independently of measuring and control devices required for operation. Our derating tables are based on a drive supply whose switching frequency is equal to or greater than 3 kHz.

ADAPTATION OF MOTORS

A motor is always characterised by the following parameters, which depend on the design:

- temperature class
- voltage range
- frequency range
- thermal reserve

CHANGES IN MOTOR PERFORMANCE

When power is supplied by a drive, changes are observed in the above parameters due to certain phenomena:

- voltage drops in the drive components
- current increase in proportion with the decrease in voltage
- difference in motor power supply according to the type of control (flux vector or U/f)

The main consequence is an increase in the motor current resulting in increased copper losses and therefore a higher temperature rise in the winding (even at 50 Hz).

Reducing the speed leads to a reduction in air flow and hence a reduction in cooling efficiency, and as a result the motor temperature rise will increase again.

Conversely, in prolonged operation at high speed, the fan may make excessive noise, and it is advisable to install a forced ventilation system.

Above the synchronous speed, the iron losses increase and hence cause further temperature rise in the motor.

The type of control mode influences temperature rise in the motor:

- A U/f ratio gives the fundamental voltage maximum at 50 Hz but requires more current at low speed to obtain a high starting torque and therefore generates a temperature rise at low speed when the motor is poorly ventilated.
- Flux vector control requires less current at low speed while providing significant torque but regulates the voltage at 50 Hz and causes a voltage drop at the motor terminals, therefore requiring more current at the same power.

The temperature classification was realised with an IGBT drive supply and PWM waveform, min switching frequency = 3kHz, U/f constant open loop.

CONSEQUENCES OF POWER SUPPLIED BY DRIVES

When power is supplied to the motor by a variable speed drive with diode rectifier, this causes a voltage drop (~5%).

Some PWM techniques can be used to limit this voltage drop (~2%), to the detriment of the machine temperature rise (injection of harmonics of orders 5 and 7).

The non-sinusoidal signal (PWM) provided by the drive generates voltage peaks at the winding terminals due to the significant voltage variations relating to switching of the IGBTs (also called dV/dt). Repeated overvoltages can eventually damage the windings depending on their value and/or the motor design.

The value of the voltage peaks is proportional to the supply voltage.

This value can exceed the limit voltage for the windings which is related to the wire grade, the impregnation type and the insulation that may or may not be present in the slot bottoms or between phases.

Another reason for attaining high voltage values is when regeneration phenomena

occur in the case of a driving load, hence the need to prioritise freewheel stops or stops that follow the longest permissible ramp.

7.1.2 - Minimum recommendations

The specific instructions given in the specific instruction manuals must be followed if a drive is used. In particular the following minimum requirements must be observed:

- Check that the drive switching frequency is 3 kHz minimum.
- Check that the motor has a second nameplate which give the maximum characteristics and performance levels of the motor during its use at variable speed.
- The reference voltage, usually 400V 50 Hz, is given on the motor nameplate. The drive must deliver a constant voltage/frequency ratio.
- Programme the maximum current value as well as the min and max frequency values shown on the second nameplate of the motor into the drive.
- Connect all the temperature sensors present on the motor (windings and, if relevant, bearing housings) to safety devices which are independent of those used for operation under normal conditions.



Drives and sensor connection components must be located outside hazardous zones (zones 0, 1, 2, 20, 21 and 22).

7.1.3 - Special conditions for safe use

- As standard the motors' impact resistance corresponds to "low" mechanical risk, therefore they must be installed in a low mechanical risk environment.
- The motor must be equipped with 3 thermal sensors (1 per phase) placed in or on the stator connection side winding heads (all frame sizes) and on the front bearing housing (from frame size 355) in the following cases:
 - motor supplied by frequency inverter
 - motor in a sufficient, non self-ventilated airflow (IC418)
 - motor adapted to no longer be self-ventilated (IC410)
 - motor equipped with a backstop
 - motor equipped with an auxiliary fan (IC416A) or radial fan (IC416R)
- The thermal protection devices must be connected to a device which de-energises the motor when the setting value is reached and before the maximum temperature at any point on the surface of the motor reaches the classification temperature shown on the nameplate. This device must operate under normal conditions and must be in addition to and functionally independent of any system which might be necessary for operation under normal conditions.
- When the motor is equipped with auxiliary or forced ventilation (IC416), a device must prevent the main motor operating in the absence of ventilation. Stopping the auxiliary motor must cause the main motor to stop.

- Heaters must only be supplied when there is no supply to the motor and the latter is cold. Their use is recommended for ambient temperatures of less than -20°C.
- Supply voltages and frequencies must comply with those stated on the motor nameplate.
- The frequency range stated on the motor nameplate must be strictly observed.
- In the event of several motors being supplied by the same drive, for safety reasons individual protection must be provided on each motor outlet (e.g. thermal relay).
- The specific instructions given in the specific instruction manuals must be followed if a drive is used.
- Cable glands and components must be compatible with the protection mode used for the connection portion. Alternatively, with integral cables, the motor connection must be made outside the explosive atmosphere or in a housing protected by a recognised protection method which is suitable for this use.
- The degree of protection of the motor, of its main connection housing and of any auxiliary connection box(es) is: IP55 - IK08. The user must provide additional protection if there is a high risk.

7.1.4 - Extreme operating conditions and specific features

MOTOR CONNECTIONS

Leroy-Somer do not recommend any specific connections for applications operating with a single motor on a single drive.

TRANSIENT OVERLOADS

Drives are designed to withstand transient overload. When the overload values are too high, the system will automatically shut down. Leroy-Somer motors are designed to withstand these overloads, however in the event of very repetitive operation we still recommend use of a temperature sensor in the winding of the motor.

STARTING TORQUE AND CURRENT

Thanks to advances in control electronics, the torque available when the motor is switched on can be adjusted to a value between the rated torque and the variable speed drive breakdown torque.

The starting current will be directly related to the torque (120 or 180%).

ADJUSTING THE SWITCHING FREQUENCY

The variable speed drive switching frequency has an impact on losses in the motor and the drive, on the acoustic noise and the torque ripple.

Low switching frequency has an adverse effect on temperature rise in motors.

Leroy-Somer recommends a drive switching frequency of 3 kHz minimum.

In addition, a high switching frequency optimises the acoustic noise and torque ripple level.

OPERATION AT SPEEDS HIGHER THAN THOSE ASSIGNED BY THE MAINS FREQUENCIES

There are risks associated with the use of asynchronous motors at high speed (speed higher than 3600 rpm):

- the cage may be damaged,
- bearing life may be impaired,
- there may be increased vibration,
- etc.

Motors are designed to operate at the speeds shown on the nameplate (do not exceed the maximum speeds stated in our technical catalogues).

When high-speed motors are used, they often need to be adapted, **and an in-depth mechanical and electrical design exercise is needed.**

CHOICE OF MOTOR

There are two possibilities:

a - The frequency inverter is not supplied by Leroy-Somer.

All the motors in this catalogue can be used with a frequency inverter.

Depending on the application, motors will need to be derated by around 10% compared to the motor operating curves in order to guarantee that motors will not be damaged.

b - The frequency inverter is supplied by Leroy-Somer

As these motor-drive assemblies have been specifically designed for use in combination, excellent performance is guaranteed.

7.1.5 - Winding insulation and recommendations relating to the mechanism of rotation

The insulation systems used for Leroy-Somer motors and recommendations for protection systems on the mechanisms of rotation are indicated in our good practice guide ref. 5626.

7.1.6 - Nameplates on motors operating with variable speed drives

The performance levels of motors operating using variable speed drives, shown on the VV nameplate, are values obtained with PWM supplies, with 360V at the motor terminals, in continuous operation.

That is, for the following two cases:

- **400V rated voltage before drive + drive voltage drop of 40V.**
- **A – 10% + drive with no voltage drop.**

Please contact us for other cases.

Some applications require special construction specifications:

- Do not use a motor for lifting that is not rated S3 or S4.
- Do not use the motor with a different duty type from that on the nameplate and in particular not in lifting applications.

8 - ADJUSTMENT

Tolerances and adjustments

Standard tolerances are applicable to the mechanical characteristic values given in our catalogues. They comply fully with the requirements of standard IEC 60072-1.

- Adhere strictly to the instructions provided by the transmission device supplier.

- Avoid impacts which could damage the bearings.

Use a screw device and grease the tapped hole of the shaft extension with a special lubricant (e.g. molykote grease) to make it easier to fit the coupling.

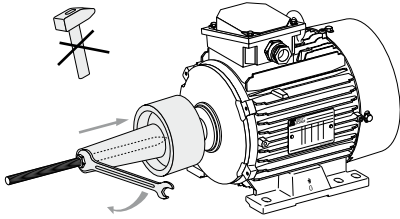

The hub of the transmission device must be :

- Fully in contact with the shoulder of the shaft or, if this is missing, hard up against the metal stop ring to form a labyrinth seal and thus lock the bearing in place (do not crush the seal);
- longer than the shaft extension (by 2 to 3 mm) so that it can be tightened using a screw and washer. If it is not, a spacer ring must be inserted without cutting the key (if this ring is large, it must be balanced).

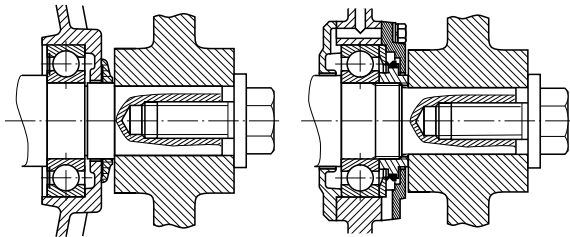

Supported on the shaft shoulder

Supported on the stop ring

In the case of a second shaft extension, it must only be used for direct coupling and the same recommendations must be followed.

⚠ The 2nd shaft extension may also be smaller than the main shaft extension and may under no circumstances supply torques greater than half the rated torque.

Inertia flywheels must not be mounted directly onto the shaft extension, but installed between bearing housings and connected by a coupling sleeve.

Direct connection to the machine

When mounted directly on the motor shaft extension of the moving device (pump or fan turbine), check that this device is perfectly balanced and that the radial force and the axial thrust are within the limits indicated in the catalogue for bearing performance.

Direct connection using a coupling sleeve

Selection of the coupling sleeve should take account of the rated torque to be transmitted and the safety factor dependent on the starting conditions for the electric motor.

The machines must be carefully aligned, so that any lack of concentricity and parallelism in the two coupling halves is compatible with the coupling sleeve manufacturer's recommendations.

The two parts of the coupling sleeve should be temporarily assembled to make it easier to alter their relative position.

Adjust the parallel plane of both shafts using a gauge. Measure the distance between the two coupling surfaces at one point on the circumference. Rotate them 90°, 180° and 270° in relation to this initial position, and measure each time. The difference between the two extreme values of dimension "x" must not exceed 0.05 mm for standard couplings.

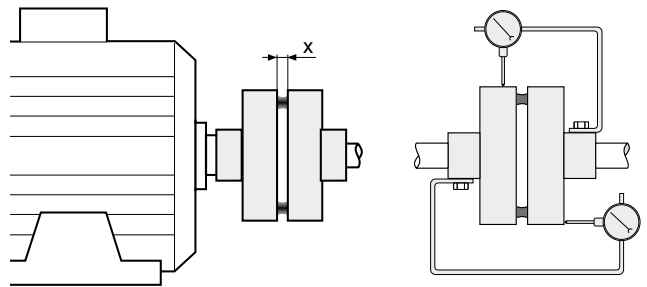

To perfect this adjustment and at the same time check the concentricity of the two shafts, fit 2 gauges as shown in the diagram and slowly turn both shafts.

The deviations registered by either shaft will indicate the need for an axial or radial adjustment if the deviation exceeds 0.05 mm.

Direct connection using a rigid coupling

The two shafts must be aligned so as to adhere to the coupling sleeve manufacturer's tolerances.

Maintain the minimum distance between the shaft extensions to allow for expansion of the motor shaft and the load shaft.

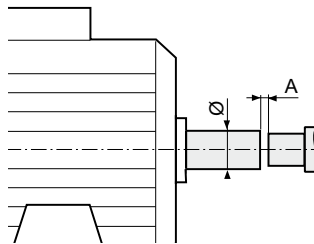

∅ (mm)	A (mm) min
9 to 55	1
60	1.5
65	1.5
75	2
80	2

Transmission via belt pulleys

⚠ When fitting a pulley/belt, check that the motor withstands the radial loads.

The user chooses the diameter of the pulleys.

Cast iron pulleys with a diameter over 315 are not recommended for rotation speeds of 3,000 rpm.

Flat belts cannot be used for rotation speeds of 3,000 rpm or more.

Positioning the belts

⚠ The belts must be anti-static and flame propagation must only occur with difficulty.

So that the belts can be correctly positioned, allow for possible adjustment of approximately 3 % with respect to the calculated distance E.

Force must never be used when fitting the belts.

For notched belts, position the notches in the pulley grooves.

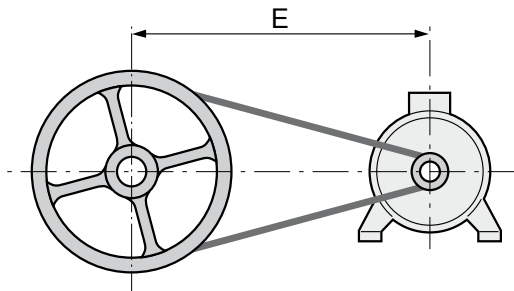

Aligning the pulleys

Check that the motor shaft is completely parallel with that of the receiving pulley.

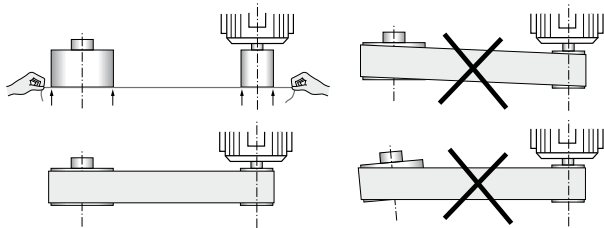

⚠ Protect all rotating devices before power-up.

Adjusting the belt tension

The tension of the belts must be adjusted very carefully in accordance with the recommendations of the belt supplier and the calculations made when the product was specified.

Reminder:

- tension too great = unnecessary force on the bearing housings which could lead to premature wear of the bearing unit (bearing housing-bearings) and eventually break the shaft;
- too little tension = vibration (wearing of the bearing unit).

Fixed distance between centres:

Place a belt tensioning pulley on the slack side of the belts:

- smooth pulley on the outside of the belt;
- grooved pulley on the inside of the belts when using V-belts.

Adjustable distance between centres:

The motor is usually mounted on slide rails, which enables optimum adjustment of the pulley alignment and the belt tension.

Place the slide rails on a perfectly horizontal baseplate.

The lengthways position of the slide rails is determined by the length of the belt, and the crossways position by the pulley of the machine being driven.

Mount the slide rails firmly with the tension screws in the direction shown in the diagram (the slide rail screw on the belt side between the motor and the machine being driven).

Fix the slide rails to the baseplate and adjust the belt tension as before.

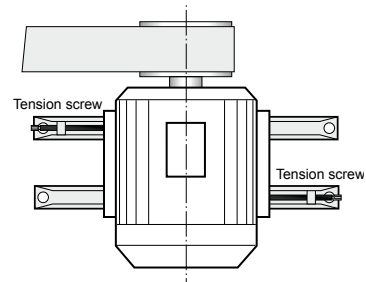

Thermal protection

In-line protection

Adjusting the thermal protection (see § 6)

It must be set to the current value shown on the motor nameplate for the voltage and frequency of the connected supply.

9 - MAINS CONNECTION

9.1 - Terminal box

If the threaded hole(s) of the orifice(s) intended to receive cable gland(s) or conduit(s) have/has ISO metric threads, there is no specific marking present on the motor. If the type of thread is different or mixed, the type(s) are marked on the equipment.

It is placed as standard on top and at the front of the motor. It offers an IP 65 degree of protection and is equipped with cable glands.

Caution: the position of the terminal box cannot easily be changed, even with flanged motors, as the condensation drain holes (if present) must be at the bottom.

Cable gland

The standard position of the cable gland is on the right when viewed from the drive end (1).

If the special position of the cable gland has not been correctly specified on the order, or is no longer suitable, the symmetrical construction of the terminal box enables it to be turned in 4 directions except for position (2) for motors with smooth holed flanges (B5).

A cable gland must never open upwards.

Check that the incoming cable bend radius prevents water entering via the cable gland.

Terminal box positions

Cable gland positions

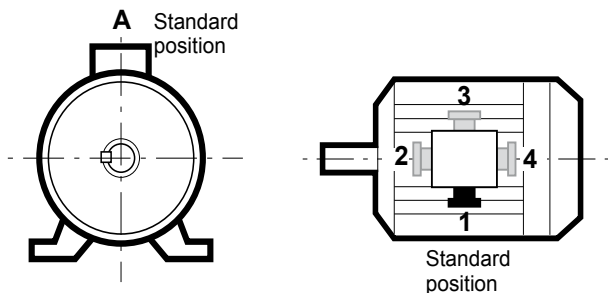

Cable size

Match the cable gland and any associated expander or reducer to the diameter of the cable used, in accordance with the specific instructions for the cable gland.

In order to maintain the motor's original IP protection, it is essential to ensure leak-tightness between the rubber ring and the cable by tightening the cable gland correctly (so that it cannot be unscrewed by hand).

Unused cable glands must be replaced by threaded plugs.

Unused orifices must also be blocked off using threaded plugs. It is essential to ensure that the fitting of cable glands or blanking devices is carried out with a seal, silicone or polyurethane sealant being made between the cable glands, the plugs, the reducers and (or) expanders, the support or the box body.

Where conduit glands are used for connection, thread leak tightness may be enhanced using grease. These threads must be sealed using silicone or polyurethane sealant or bonded using thread locking compound.

Installers are responsible for ensuring that the leak-tightness of cable passages is achieved (see the motor nameplate and the cable gland fitting instructions).

All accessories must be of a type that is attested or certified for the group, the application (gas and/or dust) and the temperature class which correspond as a minimum to those for the location of the equipment.

AVERTISSEMENT



WARNING

NE PAS OUVRIR SOUS TENSION
NE PAS OUVRIR SI UNE ATMOSPHERE
EXPLOSIVE PEUT ETRE PRESENTE
DO NOT OPEN WHEN ENERGIZED
DO NOT OPEN WHEN AN EXPLOSIVE
ATMOSPHERE MAY BE PRESENTE

ref. H551A.31
PSI070EA050

Motors are factory-fitted with warning labels which must be kept legible.

Under no circumstances must the cable be used for handling the motor.

9.2 - Connection to the electrical supply:

Connection to external power circuits must be in accordance with requirements of the standard IEC/EN 60079-14 and the regulations that are in force.

Alternatively, with integral cables the motor connection must either be made outside the explosive atmosphere, or protected by a protection method that is suitable for the application (gas and/or dust) and the temperature class which corresponds at least to that of the location of the equipment (see the information on the nameplate). Cables must be class C2 minimum and/or with gland packing.

If the motor is supplied with a cable gland support plate or un-drilled conduits:

- the drilling diameter of the smooth holes for cable glands or conduits must not be greater than the diameter of the thread of the cable gland or conduit + 2 mm and must be de-burred (broken angles about 0.5 mm x 45°) on each side of the thin plate.
- the installation of cable glands or conduit entry glands by the installer must ensure that the degree of safety (preservation of the explosion-proof character and/or of the IP) required by the application (gas and/or dust) and the motor temperature class is preserved.

If the motor is supplied with drillings but without cable or conduit glands:

- the installation of cable glands or conduit entry glands by the installer must ensure that the degree of safety (preservation of the explosion-proof character and/or of the IP) required by the application (gas and/or dust) and the motor temperature class is preserved.

If the motor is supplied with holes for cable glands blocked using non-certified plugs, replace them using components which are certified for the group, the application (gas and/or dust) and the temperature class which correspond at least to those of the motor: cable glands if connection, or plugs if unused orifices.

Adaptors (expanders or reducers) underneath plugs are prohibited. 1 adaptor only is allowed per cable gland.

If the connection box is type “eb” and comprises one or more threaded holes intended to receive cable glands, then unless stated otherwise these threaded holes are of the “ISO” type.

Supply voltages and frequencies must comply with those stated on the motor nameplate. Please contact us for all other conditions relating to the power supply.

Make connections as per the coupling instructions on the nameplate and the wiring diagram contained in the terminal box. Check the direction of rotation of the motor (§9.4).

The choice of connection cables is determined by the current, the voltage, the length and the temperature “T.cable” (if shown on the motor nameplate).

The connection must meet the requirements of the installation rules set by the standards and application of the regulations that are in force. A qualified person must be responsible for the connection, who will ensure:

- * conformity of the connection box (protection mode Ex, IP, IK etc...).

- * conformity of the connection to the terminal block and tightening torques.

- * that the air gaps required by standards are observed; where rotation is not prevented by the connection component, by the barrel insulation of each power supply cable connector using adhesive bonded heat-shrink sleeving. This sleeve must cover the cable over a length of at least 15 mm. From each terminal place the cables fitted with their connectors parallel to one another in order to achieve the maximum insulation distances.

The fastenings used for connecting cables must be of the same nature as the terminals (do not fit steel fastenings on brass terminals, for example).

When the motor is equipped with an auxiliary fan, this must be of a type that is certified for the group, the application (Gas and/ or dust) and the temperature class that corresponds at least to that of the main motor. The supplies to both motors must be connected such that energisation of the main motor must be dependent on energisation of the auxiliary motor. Stopping the auxiliary motor must cause de-energisation the main motor. The installation must include a device which prevents the main motor from operating if there is no ventilation.

Do not connect the motor if you are unsure how to interpret the connection circuit diagram or if the latter is missing: please contact us.

Installers are responsible for ensuring that the rules for electrical compatibility in the country in which the products are used are followed.

9.3 - Terminal block connection wiring diagram

All motors are supplied with a wiring diagram in the terminal box. If necessary this wiring diagram should be requested from the supplier, stating the type and number of the motor shown on the motor nameplate.

The connector links required for coupling can be found inside the terminal box.

Single speed motors are fitted with an Ex safety block of 6 terminals, with the terminal markings complying with IEC 60034-8 (or NFC 51-118).

9.4 - Direction of rotation

When the motor is running in U1, V1, W1 or 1U, 1V, 1W from a direct mains supply L1, L2, L3, it turns clockwise when seen from the main drive shaft end.

If any two of the phases are changed over, the motor will run in the reverse direction (make sure that the motor has been designed to run in both directions).

If the motor is fitted with accessories (thermal protection or space heater), these may be connected: either to strip terminals of a certified type, or to non-certified terminal strips.

Motor equipped with a terminal block

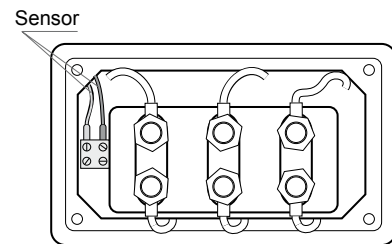

9.5 - Earth terminal and earthing



The motor must be earthed in accordance with the applicable regulations (protection of workers).

An earth terminal is located inside the terminal box and another outside the on the cover. They are indicated by the symbol: \perp

Jumper screws, lock washers, screws or lock-nuts or thread-locking compound must be used to ensure that they do not become loose.

Cable sizing must be in accordance with the requirements of standard 60079-0.

Earth cable cross-sections as a function of motor supply cable cross-sections:

Phase conductor cross-section in mm ²	Min earth or protection conductor cross-section mm ²
4	4
6	6
10	10
16	16
25	25
35	25
50	25
70	35
95	50
120	70
150	75
185	95
240	120
300	150
400	200

9.6 - Connecting the power supply cables to the terminal block

The cables must be fitted with connectors suitable for the cable cross-section and the terminal diameter (diagram 1 and 3). They must be crimped in accordance with the connector supplier's instructions.

9.6.1 - Ex eb ring connector terminal block

These terminal blocks allow standard round connectors to be used. They are fitted to the housing and held by 2 locked screws.

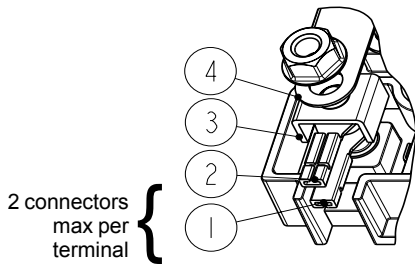

- The following are positioned, in order, on each terminal:
- 1 : the motor cable connector, barrel immobilised,
 - 2 : the power supply cable connector, barrel immobilised,
 - 3 : the anti-rotation jumper screw,
 - 4 : the Y or Δ connector links,

Tightening torque (N.m) on the slotted terminal block nuts

Terminal	M4	M5	M6
Steel	2	3.2	5
Brass	1	2	3

9.6.2 - Slotted terminal block (LSN 180 to 280)

The motor winding connection cable is fixed to the slotted terminal connector either of the soldered KA type (open barrel) made of tinned brass, or of the QUCA type (closed barrel) made of tinned copper and crimped using a suitable pliers. The mains connection cable is placed in the terminal slot, beneath the connector, and tightened to the recommended tightening torque, at the same time as the connector and the connector link, using the nut.

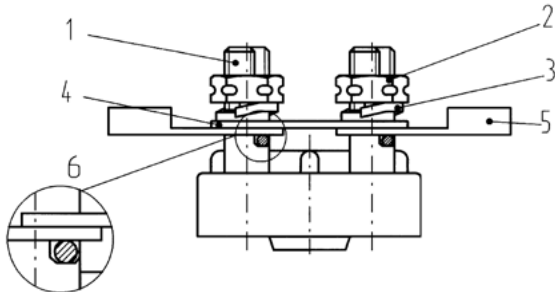

- 1: slotted terminal
- 2: retaining nut
- 3: lock washer
- 4: connector links
- 5: winding connection connector
- 6: slot for mains supply cable

Tightening torque (N.m) on the slotted terminal block nuts

Terminal	KS7A	KS8A	KS10A	KS14A	KS18A
Steel	5	6	6	10	16

Max connection cross-section for slotted terminal blocks

Terminal		KS7A	KS8A	KS10A	KS14A	KS18A
Rigid or multiple wires	mm ²	2.5	4	6	10	-
Rigid wire	mm ²	4	6	10	16	-
Max current (rigid wire)	A	35	46	63	85	-

- Earth terminal and earthing:

This is situated inside the terminal box; in some cases, the earth terminal can be situated on one of the feet or on one of the cooling fins (round motors). It is indicated by the symbol: $\frac{\perp}{\perp}$



The motor must be earthed in accordance with the applicable regulations (protection of workers).

*If necessary this wiring diagram should be requested from the supplier, stating the type and number of the motor shown on the motor nameplate.

- Connecting the power supply cables to the terminal block:

The cables must be fitted with connectors suitable for the cable cross-section and the terminal diameter.

They must be crimped in accordance with the connector supplier's instructions.

They must be connected with connector resting on connector (see diagrams below):

9.6.3 - Terminal block without slot

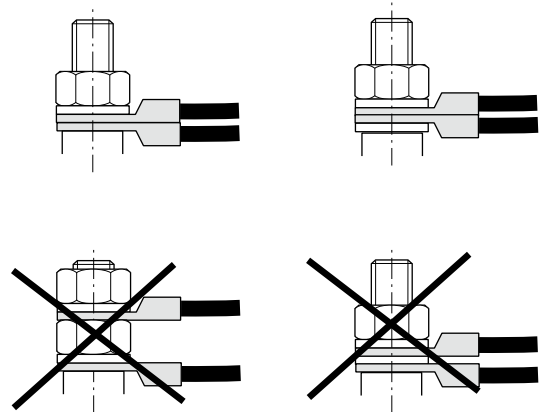

Tightening torque (N.m) on the terminal block nuts

Terminal	M4	M5	M6	M8	M10	M12	M16
Steel	2	3.2	5	10	20	35	65
Brass	1	2	3	6	12	20	50

9.6.4 - Connections

- Connection of auxiliaries on the three-pole Bartec terminal strips ref. 07-9702-0320/1 (AECE: PTB99 ATEX 3117 U - IECEx PTB 07.0007U) provided for auxiliaries (sensors, heaters etc.). :

* max tightening torque: 0.4 N.m

* max total cross-section per connection: 2.5 mm²

* U_{max} = 440V - I_{max} = 23A for example

* Min air gaps = 8

- Positioning of power connection connectors (in “eb” and “ec” box)

Positioning of stator power supply cables on the terminal block

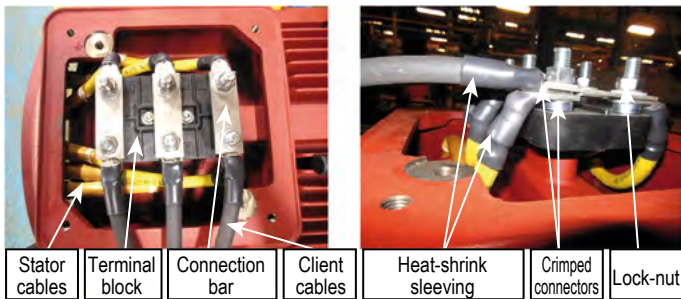

Cables must be parallel with each other in order to ensure that the 14 mm air-gap distances between phase and between phase and earth are achieved.

For FLSN motors with frame sizes 250 to 355 (terminals M10 and M12), the stator supply cable cross-section must be 35 mm² minimum.

Creepage distances and air gap requirements must be observed and must comply with the requirements of standard IEC/EN 60079-7 for the assigned voltage.

9.7 - Indication of cable gland size and type for 400V rated supply voltage if drillings required without details of hole diameters being given

Series	Type	Polarity	Power + auxiliaries	
			Number of holes	Hole diameter
FLSN	80	2;4;6	1 (2 if auxiliaries)	ISO M20 x 1.5 (1M20 + 1M16)
	90	2;4;6		
	100	2;4;6		
	112	2;4;6		ISO M25 x 1.5 (1M25 + 1M16)
	132	2;4;6		
	160	2;4;6		
	180 MR	2;4;6		ISO M32 x 1.5 (1M32 + 1M16)
	180 M/L/LUR	2;4;6		
	200	2;4;6		
	225 SR/MR	2;4;6		ISO M40 x 1.5 (1M40 + 1M16)
	225 M	2;4;6		ISO M50 x 1.5 (1M50 + 1M16)
	250	2;4;6		ISO M63 x 1.5 (1M63 + 1M16)
	280	2;4;6		ISO M75 x 1.5 (1M75 + 1M16)
	315	2;4;6		
	355	2;4;6		

Series	Type	Polarity	Terminal box material	Power + auxiliaries	
				Number of holes	Hole diameter*
LSN	80	2;4;6	Aluminium alloy	1 (2 if auxiliaries)	ISO M20 x 1.5 (1M20 + 1M16)
	90	2;4;6			
	100	2;4;6			
	112	2;4;6		2 (3 if auxiliaries)	ISO M25 x 1.5 (2M25 + 1M16)
	132	2;4;6			
	160	2;4;6			
	180	2;4;6		3	2 x M40 + 1 x M16
	200	2;4;6			
	225	2;4;6			
	250 MZ	2		2 x M50 + 1 x M16	
	250 ME	4;6			
	280	2;4;6			
				2 x M63 + 1 x M16	

* As an option, both ISO M25 holes may be replaced by 1 ISO x M25 and 1 ISO x M32 (to comply with standard DIN 42925).

9.8 - Admissible number and maximum size of holes for cable glands per “eb” terminal block

- FLSN 160 to 225: 4 ISO20 or 2 ISO40 + 2 ISO20.
- FLSN 250 & 280: 8 ISO20 or 2 ISO75 + 2 ISO20.
- FLSN 315 & 355: 10 ISO20 or 2 ISO83 + 2 ISO20.
- FLSN \geq 400: 14 ISO40 or 4 ISO90 + 4 ISO20.

9.9 - Cable temperatures (T_{cable})

- * For $T^{\circ}\text{amb} \leq 40^{\circ}\text{C}$: no T° cable.
- * For $40^{\circ}\text{C} < T^{\circ}\text{amb} \leq 50^{\circ}\text{C}$: T° cables 80°C .
- * For $50^{\circ}\text{C} < T^{\circ}\text{amb} \leq 60^{\circ}\text{C}$: T° cables 90°C .

10 - MAINTENANCE

10.1 - General

10.1.1 - Frequent monitoring

The frequency of inspections depends on specific climatic and operating conditions, and will be established in accordance with experience acquired.

The purpose of this monitoring, which is in general carried out by operating personnel is:

- to monitor, for preventative purposes, the condition of equipment (cables, cable glands etc.) taking the environment (temperature, humidity etc.) into consideration,
- to detect any anomalies as soon as possible; these are sometimes dangerous, such as abrasion damage to cable ducting,
- to provide a practical addition to the training of personnel on risks and means of preventing them.



Dust accumulating between the fins or/and against the fan cover grille leads to an increased surface temperature, so the motor must be cleaned regularly. Cleaning must be carried out at reduced pressure from the centre and towards the ends of the machine.

10.1.2 - Repairs

Repairs to electrical equipment which can be used in ATEX zones must only be made to the as-built specification, by qualified personnel and in accordance with the requirements of standard IEC/EN 60079-19. This requirement to return to the as-built condition, whilst scrupulously adhering to the starting configuration of the motor is mandatory. Failure to comply with this requirement may affect equipment safety (for example, protection index which is not IP compliant) or the surface temperature (e.g. rewinding of the motor). Service centres ('Centres de Service' - CDS) are "Saqr - ATEX" trained and approved in order to ensure safe maintenance and repair of these motors.

CAUTION:

All modifications made without written permission of the manufacturer are strictly prohibited.

Service Centres are trained and approved by Leroy-Somer to guarantee that these motors are safely maintained and repaired.

10.1.3 - Spare parts

When ordering spare parts, you must indicate the complete motor type, its serial number and the information given on the nameplate (see section 1).

Part references can be read from the exploded view diagrams and descriptions obtained from the parts list (§ 11).

Routine maintenance kits can be obtained from our After-Sales services.

In the case of flange mounted motors, indicate the type of flange and its dimensions (see below).

Motor with smooth hole flange

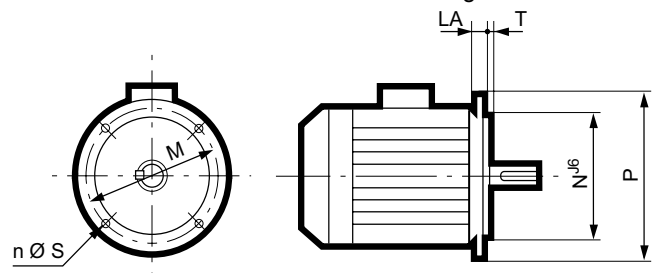

Motor with tapped holes

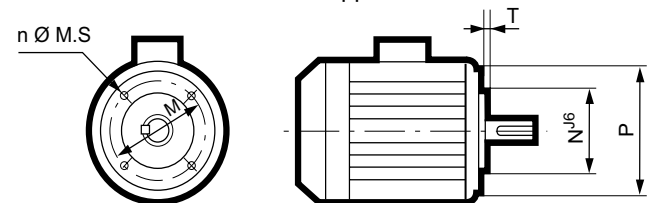

Our network of service centres can dispatch the necessary parts without delay.

Original manufacturer replacement parts must be used to ensure that our motors operate safely and correctly.

In the event of failure to comply with this advice, the manufacturer cannot be held responsible for any damage.

10.2 - Corrective maintenance: General

⚠ Corrective maintenance can only be carried out by Service Centres that are trained in and approved for the repair of ATEX products.

⚠ Shut off and lock out all power supplies before any intervention.

- Open the terminal box, identify the wires and their position,
 - disconnect the power supply wires,
 - uncouple the motor from the equipment being driven.
- To remove the equipment mounted on the motor shaft extension, an extractor must always be used.

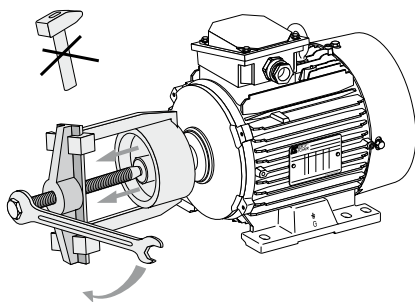

10.2.1 - Removal of the motor

Please refer to the detailed instructions given on the following pages. Flanges should be identified in relation to the stator and to the fan direction on the rotor.

10.2.2 - Checks before refitting

Stator:

- remove dust from the stator: if the winding needs to be cleaned, use a suitable liquid; dielectric and inert in terms of the insulation and paint,
- check the insulation (see § 3) and if necessary stoving must be carried out,
- carefully clean the recesses, remove all traces of impacts and of sealant on the support surfaces if necessary.

Rotor:

⚠ Replace the seals at the shaft passages, at the bearing housings using new seals of the same type, after cleaning the components. Shaft passage seals must be fitted using the same type of grease as the bearings.

- Clean and check the support surfaces; if damaged restore the support surface or change the rotor;
- check the condition of the threads, the keys and their housings.

Flanges, bearing housings:

- clean all traces of contamination (old grease, dust agglomerations, sealant etc.),
- clean bearing housings and recesses,
- if necessary apply antifeash lacquer inside the flanges,
- carefully clean the bearing caps and grease valves (if these are fitted to the motor).

10.2.3 - Fitting bearings onto the shaft

This is a critical operation. The slightest traces of ball marks left on the bearing tracks could result in noise and vibration.

Lightly grease the shaft supports.

Correct fitting can be carried out in various ways:

- cold: assembly must be performed without impact using a screw device (the use of hammers is prohibited); the fitting force must not be exerted via the bearing track, and the inner cage must therefore be used for support (take care not to rest on the sealing web for sealed bearings);
- hot: heat the bearing to 80 to 100°C: use a bearing heater or a stove, in an oven or on a hotplate.

(Heating using a blowlamp is prohibited in all cases, as is heating using an oil bath).

After removing and refitting a bearing, all gaps in seals and labyrinths must be filled with grease to prevent dust from entering and to prevent the formation of corrosion of machined parts.

See detailed instructions given on the following pages.

10.2.4 - Re-fitting the motor

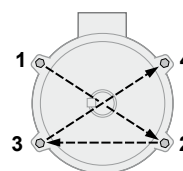

Fitting rod tightening torques

Type	Ø rod/screw	Tightening torque <i>N. m ± 5%</i>
56	M4	2.5
63	M4	2.5
71	M4	2.5
80	M5	4
90	M5	4
100	M5 or M6	4
112	M5 or M6	4
132	M7	10
160	M8	18
180 MT/LR	M8	18
180 L	M10	25
200	M10	25
225 ST/MR	M10	25
225 MK	M12	44
250	M12	44
280	M12	44
315	M12	44
315 LK / 355	M16	100
355 LK / 400	M16	100
450	M16	100

Take care to return the stator to its original position both in centring of the laminations (generally terminal box forwards) and in positioning of drain holes if these are on the frame.

Tightening of the assembly rods

Tightening is performed diagonally to the indicated torque (see above).

10.2.5 - Refitting the terminal box

Re-connect all power supply wires in accordance with the wiring diagram or the identification performed before dismantling. For terminal boxes equipped with a flared feed (item 89 in the exploded views) and/or a cable gland support plate, ensure that the seals are correctly fitted before closing. Check that the terminal box components are properly tightened.

Note: It is recommended that a no-load test of the motor is performed

- If necessary repaint the motor.
- Fit the transmission element to the motor shaft extension and install the motor once more onto the machine being driven (see § 4.3).

10.3 - Safety rules

 **Before any intervention is undertaken on the motor or the panel, check that there is not an explosive atmosphere present and that all equipment components are switched off. Also ensure that the motor is sufficiently cool to prevent any risk of burns.**

 **Before any intervention is undertaken on the motor or the panel, check that cosine compensation capacitors φ are isolated and/or discharged (read the voltage at the terminals).**

 **Before any intervention in the terminal box or in the panel, check that the heaters are de-energised.**

 **Depending on the type of thermal protection, the motor may remain energised. Ensure that the AC supply is disconnected before any work is carried out in the terminal box or in the cabinet.**

10.4 - Routine maintenance

Inspection after commissioning

After about 50 hours of operation check the tightness of the motor fixing bolts and of the coupling device. In the case of chain or belt drives, check that the tension is correctly adjusted.

Cleaning

To ensure the motor operates correctly, remove any dust or foreign bodies which might clog the air inlet and the housing fins. Necessary precaution: check that the motor is totally sealed (terminal box, drain holes, etc.) before carrying out any cleaning operation.

Dry cleaning (vacuuming or compressed air) is always preferable to wet cleaning.

Under no circumstances can cleaning of the motor generate an electrostatic charge.

 **Always clean at a pressure of less than 10 bars from the centre of the motor towards the extremities to avoid introducing dust and particles under the seals.**

Draining off condensation water

Temperature differences cause condensation to be produced inside the motor. Condensation must be removed before it adversely affects motor operation.

Condensation removal holes located at the low points of the motors, depending on operating position, are blocked off using plugs which must be removed and refitted every six months.

Note: In conditions of high humidity and significant temperature variations, or an extended shut-down, a shorter period is recommended.

 **Condensation drain holes must only be open during maintenance operations.**

 **Refit the drain hole plugs in place to ensure the IP degree of protection plated on the motor. Replace the seals that are removed using new seals with the same characteristics. Clean the orifices and plugs before refitting them.**

10.4.1 - Greasing

10.4.1.1 - Service life of grease

The service life of lubricating grease depends on:

- the characteristics of the grease (nature of the soap, of the base oil etc.),
- operational constraints (bearing size and type, speed of rotation, operating temperature etc.),
- contamination factors.

10.4.1.2 - Permanently greased roller bearing housings

For (F)LSN motors of type less than or equal to 180, the bearings specified allow a long service life to be achieved for the grease, and therefore machines can be permanently greased. The service life of the grease as a function of the speeds of rotation and of the ambient temperature is indicated in the following chart.

FLSN permanently greased bearings:

Series	Type	Polarity	Types of permanently greased bearings	
			N.D.E.	D.E.
FLSN	80 L	2	6203 CN	6204 C3
	80 LG	4		
	90 S	2; 4; 6	6204 C3	6205 C3
	90 L	4		
	90 LU	2; 6	6205 C3	6205 C3
	100 L	2; 4		
	100 LK	4; 6	6205 C3	6206 C3
	112 MG	2; 6		
	112 MU	4	6206 C3	6206 C3
	132 S	2; 4; 6	6207 C3	6308 C3
	132 M	6		
	132 MU	2; 4	6307 C3	6308 C3
	132 MR	4; 6	6308 C3	6308 C3
	160 M	2; 4; 6	6210 C3	6309 C3
	160 L	6		
	160 LU	2; 4	6210 C3	6309 C3
		6	6210 C3	6309 C3
	180 M	2	6212 C3	6310 C3
	180 MR	4	6210 C3	6310 C3
	180 L	6	6212 C3	6310 C3
	180 LUR	4	6312 C3	6310 C3
	200 LU	2; 4; 6	6312 C3	6312 C3
225 SR	4	6312 C3	6313 C3	
225 M	4; 6	6314 C3	6314 C3	
225 MR	2	6312 C3	6313 C3	

Note: all motors can be equipped with grease nipples on request.

LSN permanently greased bearings:

Series	Type	Polarity	Types of permanently greased bearings	
			N.D.E.	D.E.
LSN	80 L	2	6203 CN	6204 C3
	80LG	2;4		
	90 S - L	2;4;6	6204 C3	6205 C3
	90 LU	4	6205 C3	6205 C3
	100 L	2;4;6	6205 C3	6206 C3
	100 LR	4		
	112 MR	2		
	112 MG	2;6	6205 C3	6206 C3
	112 MU	4	6206 C3	6206 C3
	132 S	2;6		
	132 SU	2;4	6206 C3	6208 C3
	132 M	2;4;6	6207 C3	6308 C3
	132 MU	4;6	6307 C3	6308 C3
	160 MR	2;4	6308 C3	6309 C3
	160 MP	2;4	6208 C3	6309 C3
	160 M	6		
	160 LU	4;6	6210 C3	6309 C3
	160 L	2;4		
	180 MT	2;4		
	180 LR	4	6210 C3	6310 C3
	180 LUR	4;6	6312 C3	6310 C3
	180 L	6	6212 C3	6310 C3
	200 LR	2;4;6	6312 C3	6312 C3
	200 L	2;6	6214 C3	6312 C3
	200 LU	2;6	6312 C3	6312 C3
	225 ST	4		
	225 MT	2	6214 C3	6313 C3
	225 MR	2;4;6	6312 C3	6313 C3
225 MG	2;4;6	6216 C3	6314 C3	

Note: all motors can be equipped with grease nipples on request except 132 S/SU.

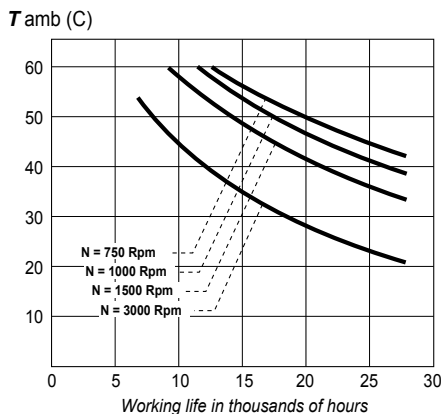

10.4.1.3 - Roller bearings housings with grease nipples

The bearings are lubricated in the factory.

The instructions required for bearing housing maintenance are shown on the machine nameplate.

For (F)LSN motors of frame size equal to or greater than 200, the bearing housings are fitted with bearings lubricated by Télalémit-Hydraulic M8 x 125 type grease nipples.

⚠ The frequency of lubrication and quantity and quality of grease are indicated on the nameplates. Refer to these to ensure correct greasing of the bearings.

⚠ The interval between greasing operations must never, under any circumstances, exceed 2 years, even in the event of prolonged storage or downtime.

10.5 - Bearing housing maintenance

10.5.1 - Checking bearings

As soon as you detect any of the following on the motor:

- abnormal noise or vibration,
 - abnormal heating at the bearing although it is properly greased, the condition of the bearings must be checked.
- Damaged bearings must be replaced as soon as possible to prevent worse damage to the motor and the equipment being driven.

When one bearing needs to be replaced, the other bearing must also be replaced.

The free bearing must allow the rotor shaft to expand (check its identification during dismantling).

10.5.2 - Refurbishing bearing housings

Roller bearings without grease nipples

Remove the motor (see § 10.2.1); remove the old grease (if the bearings are not of the sealed type) and clean the bearings and accessories using degreaser.

Apply new grease: the bearing housing must be filled to 50% of the free volume with new grease.

Roller bearings housings with grease nipples

Always start by cleaning old grease from the channel

When the plated grease type is used, remove the covers and clean the grease nipple heads.

When a grease other than the plated grease type is used, the motor must be dismantled and bearings and accessories cleaned using degreaser (carefully clean the grease inlet and discharge channels) to remove all old grease before greasing once more.

To ensure correct lubrication the internal free volumes of caps, flanges must be filled and 30% of the free volume of bearings. Then rotate the motor to distribute the grease.

Warning!

To great a quantity of grease can cause excessive heating of the bearing (statistically the number of bearings damaged by excess grease is greater than the number of bearings damaged by lack of greasing).

⚠ Do not mix different types of grease (even if the soap bases are the same). Non-miscible lubricants can damage the bearings.

Important! Please note

The new grease must have been recently manufactured, and must have equivalent performance levels and must not contain any impurities (dust, water or other impurities).

Bearings may be electrically insulated. Their type of marked on the nameplate.

FLSN bearings with grease nipples:

Series	Type	Polarity	Type of bearings for bearing housings with grease nipples		Quantity of grease g	Lubrication intervals in hours								
			N.D.E.	D.E.		3000 rpm			1500 rpm			1000 rpm		
						25°C	40°C	55°C	25°C	40°C	55°C	25°C	40°C	55°C
FLSN	160 M*	2; 4; 6	6210 C3	6309 C3	13	17600	8800	4400	25800	12900	6450	29200	14600	7300
	160 L*	6			13	-	-	-	-	-	-	29200	14600	7300
	160 LU*	2; 4			13	17600	8800	4400	17600	8800	4400	-	-	-
		6			15	-	-	-	-	-	-	29200	14600	7300
	180 M*	2	6212 C3	6310 C3	15	14400	7200	3600	-	-	-	-	-	-
	180 MR*	4	6210 C3	6310 C3	15	-	-	-	24200	12100	6050	-	-	-
	180 L*	6	6212 C3	6310 C3	20	-	-	-	-	-	-	27800	13900	6950
	180 LUR*	4	6312 C3	6310 C3	20	-	-	-	21400	10700	5350	-	-	-
	200 LU*	2; 4; 6	6312 C3	6312 C3	20	12000	6000	3000	21400	10700	5350	25000	12500	6250
	225 SR*	4	6312 C3	6313 C3	25	-	-	-	20000	10000	5000	-	-	-
	225 M*	4; 6	6314 C3	6314 C3	25	-	-	-	18800	9400	4700	25400	12700	6350
	225 MR*	2	6312 C3	6313 C3	25	10600	5300	2650	-	-	-	-	-	-
	250 M	2; 4; 6	6314 C3	6314 C3	25	9400	4700	2350	18800	9400	4700	25400	12700	6350
	280 S/M	2; 4; 6	6314 C3	6316 C3	35	7200	3600	1800	21000	13230	6615	29000	29000	18270
	315 S/M/L	2	6316 C3	6218 C3	35	7400	5880	2920	-	-	-	-	-	-
	315 S/M/L	4; 6	6316 C3	6320 C3	50	-	-	-	15600	12400	6160	25000	25000	12500
	355 L	2	6316 C3	6218 C3	35	7400	3700	1850	-	-	-	-	-	-
	355 L	4; 6	6316 C3	6322 C3	60	-	-	-	13200	8316	4160	22000	13860	6930
	355 LKB	4; 6	6324 C3	6324 C3	72	-	-	-	7500	3700	2800	20000	20000	10000
	355 LKB	2	6317 C4	6317 C4	37	6600	5200	2600	-	-	-	-	-	-
	355 LKC	6	6324 C3	6324 C3	72	-	-	-	-	-	-	20000	17000	8500
400 LB	2	6317 C4	6317 C4	37	6600	5200	2600	-	-	-	-	-	-	
400 LB	4	6324 C3	6324 C3	72	-	-	-	7500	3700	2800	-	-	-	
450 LA/LB/LD	4	6328 C3	6328 C3	93	-	-	-	4600	2300	1100	-	-	-	
450 LA/LB/LC	6	6328 C3	6328 C3	93	-	-	-	-	-	-	10000	6000	3000	

* bearing housings with grease nipples on request

LSN bearings with grease nipples:

Series	Type	Polarity	Type of bearings for bearing housings with grease nipples		Quantity of grease g	Lubrication intervals in hours								
			N.D.E.	D.E.		3000 rpm			1500 rpm			1000 rpm		
						25°C	40°C	55°C	25°C	40°C	55°C	25°C	40°C	55°C
LSN	160 M*	6	6210 C3	6309 C3	13	-	-	-	-	-	-	31600	15800	7900
	160 LU*	4; 6				-	-	-	25800	12900	6450	31600	15800	7900
	160 L*	2; 4			13	17600	8800	4400	25800	12900	6450	-	-	-
	180 MT*	2; 4	6210 C3	6310 C3	15	15600	7800	3900	24200	12100	6050	-	-	-
	180 LR*	4				-	-	-	24200	12100	6050	-	-	-
	180 LUR*	4; 6	6312 C3	6310 C3	20	-	-	-	21400	10700	5350	28000	14000	7000
	180 L*	6	6212 C3	6310 C3	15	-	-	-	-	-	-	28000	14000	7000
	200 LR*	2; 4; 6	6312 C3	6312 C3	20	12000	6000	3000	21400	10700	5350	28000	14000	7000
	200 L*	2; 6	6214 C3	6312 C3	20	11600	5800	2900	-	-	-	27600	13800	6900
	200 LU*	2; 6	6312 C3	6312 C3	20	12000	6000	3000	-	-	-	28000	14000	7000
	225 ST*	4	6214 C3	6313 C3	25	-	-	-	20000	10000	5000	-	-	-
	225 MT*	2				10600	5300	2650	-	-	-	-	-	-
	225 MR*	2; 4; 6	6312 C3	6313 C3	25	10600	5300	2650	20000	10000	5000	26800	13400	6700
	225 MG*	2; 4; 6	6216 C3	6314 C3	25	9400	4700	2350	18800	9400	4700	25600	12800	6400
	250 MZ	2	6312 C3	6313 C3	25	10600	5300	2650	-	-	-	-	-	-
	250 ME	4; 6	6216 C3	6314 C3	25	-	-	-	22000	11000	5500	30000	16000	8000
	250 MF	2				11000	5500	2750	-	-	-	-	-	-
	280 SC - MC	2				-	-	-	-	-	-	-	-	-
	280 SC	4; 6	6216 C3	6316 C3	35	-	-	-	20000	10000	5000	28000	14000	7000
	280 MC	6				-	-	-	-	-	-	-	-	-
	280 MD	4	6218 C3	6316 C3	35	-	-	-	20000	10000	5000	-	-	-
280 SU	2; 4; 6	6317 C3	6317 C3	40	8000	4000	2250	18000	9000	4500	24000	12000	6000	
280 SK	6				-	-	-	-	-	-	-	-	24000	12000
315 SN	2	6216 C3	6316 C3	35	9000	4500	2250	-	-	-	-	-	-	
315 SN	6	6218 C3	6317 C3	40	-	-	-	-	-	-	24000	12000	6000	
315 MP - MR	2	6317 C3	6317 C3	40	8000	4000	2250	-	-	-	-	-	-	
315 SP	4	6317 C3	6320 C3	50	-	-	-	15000	7500	3750	-	-	-	
315 MP - MR	4; 6				-	-	-	-	-	-	-	-	24000	12000

* bearing housings with grease nipples on request

10.6 - IP Leak tightness of motor

 **WHENEVER** removed during preventative maintenance replace seals (shaft passages, bearing recesses, terminal box cover etc.) if made of sealant using new seals with the same characteristics after cleaning the components. Shaft passage seals must be fitted using the same type of grease as the bearings.

 After every removal of drain plugs, refit them to ensure the IP degree of protection plated on the motor. Replace the seals that are removed using new seals with the same characteristics. Clean the orifices and plugs before refitting them.

 After removal of the terminal box cover, replace the seal using a new seal of the same type after cleaning the components if its condition no longer guarantees the required degree of protection.

In the case of an "eb or "ec" type connection box:

- In the case of a "eb or ec" type box, if the threaded hole(s) of the orifice(s) intended to receive cable gland(s) or conduit(s) have/has metric threads, there is no specific marking present on the motor. If the type of thread is different or mixed, the type(s) are marked on the equipment.

- When closing "eb or ec" connection boxes, check that all seals are correctly positioned (bond them onto one of the components) and that the screws are correctly tightened in order to guarantee the IP degree of protection that is marked on the nameplate.

10.7 - Groups IIC (> 200 µm) and group III paints: electrostatic risk

IEC EN 60079-0 §7.4 reminder:

Preventing electrostatic charge development on an item of equipment:

Maximum thickness of non-metallic layer (paint):

Group IIB = 2 mm ; Group IIC = 0.2 mm ; Group III = no limit.

The instructions must provide users with recommendations for reducing the risk of electrostatic discharges to as great an extent as possible.

Physical effects:

- Paint gives rise to electrostatic risks due to friction: during cleaning for example.
- Charges suspended in the air may be attracted by the paint and thus give it an electrostatic charge: charge by influence.

Leroy Somer recommendations:

- Earth continuity between the various metallic parts must be ensured: frame, bearing housings, fan cover etc.
- The equipment must be permanently connected to earth.
- The motor must be cleaned using a damp cloth or using means which do not cause friction on the paint: using an ionised air-gun, for example.
- Users must prevent the paint gaining an electrostatic charge. For example: by making motor operation dependent on the level of humidity in the place it is located or by ionising the surrounding air.

Users must carry out an assessment of the electrostatic risks in order to meet the requirements of guide IEC/TS 60079-32-1

10.8 - Troubleshooting guide

Incident	Possible cause	Remedy
Abnormal noise	Originating in motor or machine being driven?	Uncouple the motor from the equipment being driven and test the motor on its own
Noisy motor	Mechanical cause: if the noise persists after cutting off the electrical supply	
	- Vibration	- Check that the key conforms to the type of balancing (see section 10.3)
	- Damaged bearings	- Change the bearings
	- Mechanical friction: ventilation, coupling	- Check
	The cause is electrical: if the noise stops after switching off the power supply	- Check the power supply at the motor terminals
	- Normal voltage and 3 phases balanced	- Check the connection of the terminal block and the tightening of the connectors
	- Abnormal voltage	- Check the power supply line
Motor heats abnormally	- Phase imbalance (current)	- Check the winding resistance and the balancing of the network (voltage)
	- Faulty ventilation	- Check the environment - Clean the fan cover and the cooling fins - Check that the fan is correctly mounted on the shaft
	- Faulty supply voltage	- Check
	- Terminal connection fault	- Check
	- Overload	- Check the current consumption in relation to that indicated on the motor nameplate
	- Partial short-circuit	- Check the electrical continuity of the windings and/or the installation
	- Phase imbalance	- Check the winding resistance
Motor does not start	No load - Mechanical obstruction - Broken power supply line	When switched off: - turn the shaft by hand to check that it rotates freely - check fuses, electrical protection, starting device, electrical continuity
	On load - Phase imbalance	When switched off: - Check the direction of rotation (phase order) - Check the resistance and continuity of the windings - Check the electrical protection

10.9 - Preventive maintenance

Consult LEROY-SOMER, who offer a preventive maintenance system through its **Maintenance Industrie Services** network. This system enables data to be obtained on site of the parameters at different points as indicated in the table below. A computer analysis is then performed using these measurements to produce a report on the behaviour of the installation. This report highlights problems such as eccentricity, misalignment, the condition of the bearings as well as structural problems, electrical problems, etc.

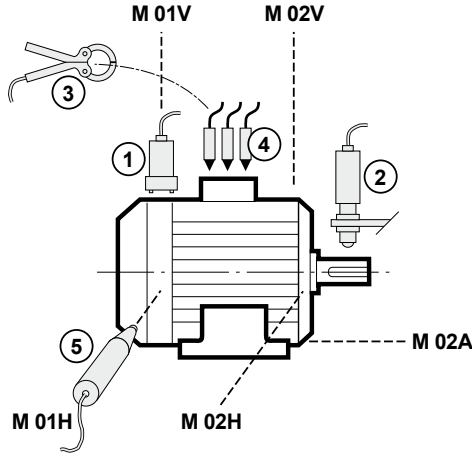

Detector	Measurement	Measurement points position								
		M 01V	M 01H	M 02V	M 02H	M 02A	Shaft	E01	E02	E03
① Accelerometer	Vibration	●	●	●	●	●				
② Photo-electric cell	Speed and phase measurement (balancing)						●			
③ Clamp-on ammeters	Current (DC or 3-phase AC) measurement							●	●	●
④ Voltage probe	Voltage							●	●	●
⑤ Infra-red probe	Temperature	●		●						

10.10 - Recycling

- It is recommended that at the end of a motor’s working life a material recovery organisation is approached to recycle the various components of the motor.



11 - REMOVAL AND REFITTING PROCEDURE

(Drawings do not foresee the construction's details)

11.1 - LSN 80 to LSN 160 MP/LR FLSN 80 to 132 motors

11.1.1 - Removal

- Remove the cover (13) once the screws (27) are removed;
- extract the fan (7) using a hub puller or failing this two diametrically opposite levers (e.g. screwdrivers) supported on the flange (6);
- withdraw the assembly rods (14);
- withdraw the key (21);
- using a wooden mallet, tap the fan side of the shaft to release the shaft extension side flange (5);
- remove the rotor shaft (3) and front flange (5) avoiding making contact with the winding;
- withdraw the fan side flange (6);
- recover the pre-load washer (59) and the rear flange seal (54) for motors LS 100, 112 and 132;
- withdraw the circlips (60) on flanged motors using an elbowed circlips pliers;
- separate the front flange from the rotor shaft;
- the shaft is then seen with its 2 bearings and where relevant the circlips.

To remove the bearings use a bearing puller and avoid making contact with the shaft support surface.

11.1.2 - Refitting motor without circlips

- Fit the bearings on the rotor shaft;
- introduce the rotor into the stator taking all precautions not to make contact with the winding;
- fit the front flange (5);
- fit the rear flange (6) after placing the pre-load washer (59) in the bearing housing;
- place the assembly rods in position (14) and tighten the nuts diagonally to the recommended torque (see § 10.2.4);
- fit the flange seals (39, 54, 308) using grease;
- fit the fan (7) wedging it in place with a drift;
- check that the motor turns freely by hand and that there is no radial play;
- refit the cover (13) and fix it in place with the screws (27).

11.1.3 - Refitting motor with flange and circlips

- Fit the front bearing (30) in the flange (5) resting supported on the outer ring ;
- fit the circlips (60);
- fit this assembly on the rotor (3) resting on the interior bearing ring;
- fit the rear bearing on the rotor;
- introduce the rotor (3) flange (5) assembly into the stator taking all precautions not to make contact with the winding;
- fit the rear flange (6) after placing the pre-load washer (59) in the bearing housing;
- place the assembly rods in position (14) and tighten the nuts diagonally to the recommended torque (see § 10.2.4);
- fit the flange seals (39, 54, 308) using grease;
- fit the fan (7) wedging it in place with a drift;
- check that the motor turns freely by hand and that there is no axial play;
- refit the cover (13) and fix it in place with the screws (27);
- refit the key (21).

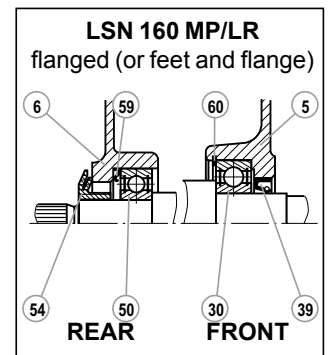
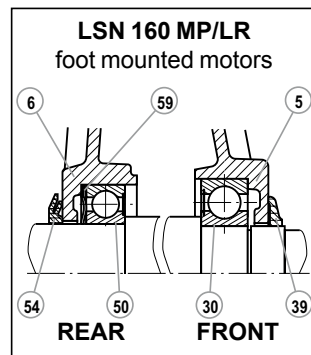
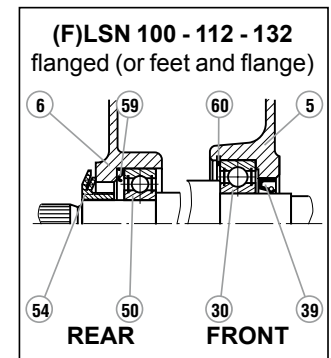
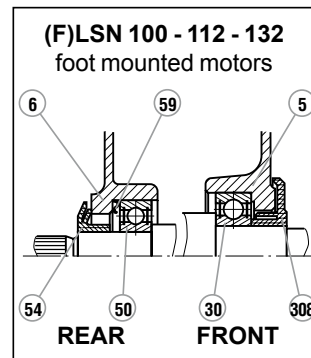
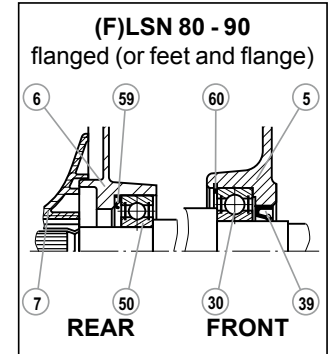
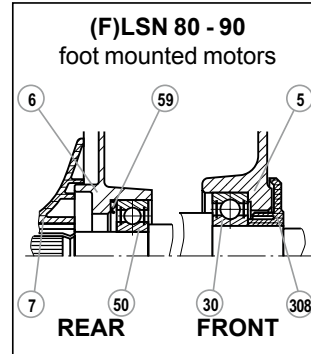

11.2 - LSN 160 M/L, LSN 180 MT/LR motors

11.2.1 - Removal

- Remove the cover (13) once the screws (27) are removed;
- extract the fan (7) using a hub puller or failing this two diametrically opposite levers supported on the flange (6);
- remove the key (21) and withdraw the seals (39 and 54) for motors with feet, (39) for flanged motors);
- unscrew the assembly rods (14) then withdraw them;
- unscrew the fixing screws (40) of the inner cover (33);
- using a bronze drift, extract the flanges (5 et 6) by gently tapping on the flange pad; recover the pre-load washer (59);
- withdraw the circlips (38) if necessary (flange motor);
- remove the rotor (3) from the stator (1) taking care not to touch the winding;
- extract the bearings (30) and (50) with a bearing puller whilst protecting the shaft end with a washer; avoid making contact with the shaft support surface.

11.2.2 - Re-fitting

- See § 10.2.4 before refitting;
- introduce the rotor front side inner cap (33) then refit the new bearings onto the shaft.
- fit the circlips (38) for flanged motors;
- introduce the rotor (3) into the stator (1) taking all precautions not to make contact with the winding;
- fit the pre-load washer (59) with a little grease in the bottom of the rear flange bearing cage (6), then refit the rear flange (6), positioning it on the stator;
- for fitting the cap (33), screw a threaded rod of the same diameter as the screws (40) into one of the threaded holes of the cap to ensure the correct angular positioning during refitting of the front flange (5); for a flange, fit a new seal (39) spring towards the exterior;
- refit the flange (5) taking care with the positioning of any cap;
- place the assembly rods in position (14) and tighten the nuts diagonally to the recommended torque (see § 10.2.4);
- fix the cap with its screws (33);
- fit the new flange seals with grease (54) to the rear, (39) to the front for motors with feet;
- fit the fan (7) wedging it in place with a drift;
- check that the rotor turns freely by hand (and that there is no axial play if there is an immobilised bearing);
- refit the cover (13) and fix it in place with the screws (27);
- refit the key (21).

Bearings housings must be fitted with a front interior cap.

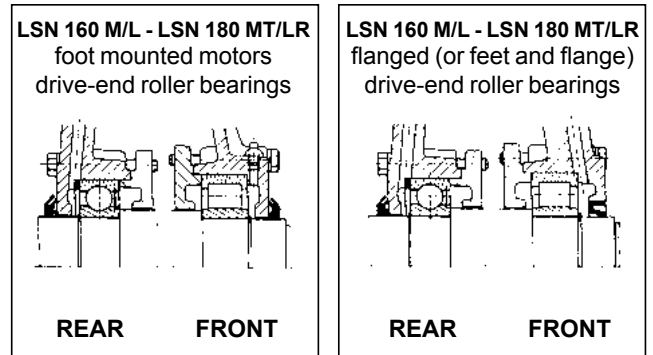
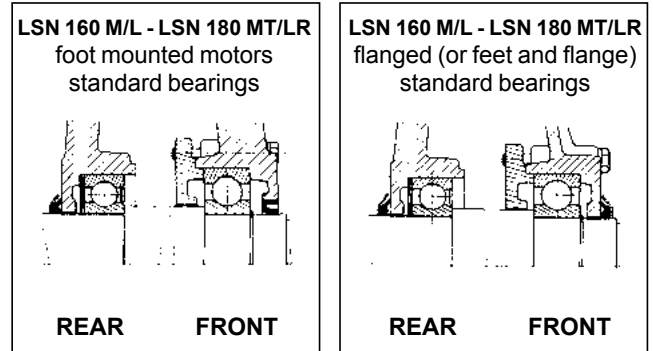

LSN 160 M/L, LSN 180 MT/LR

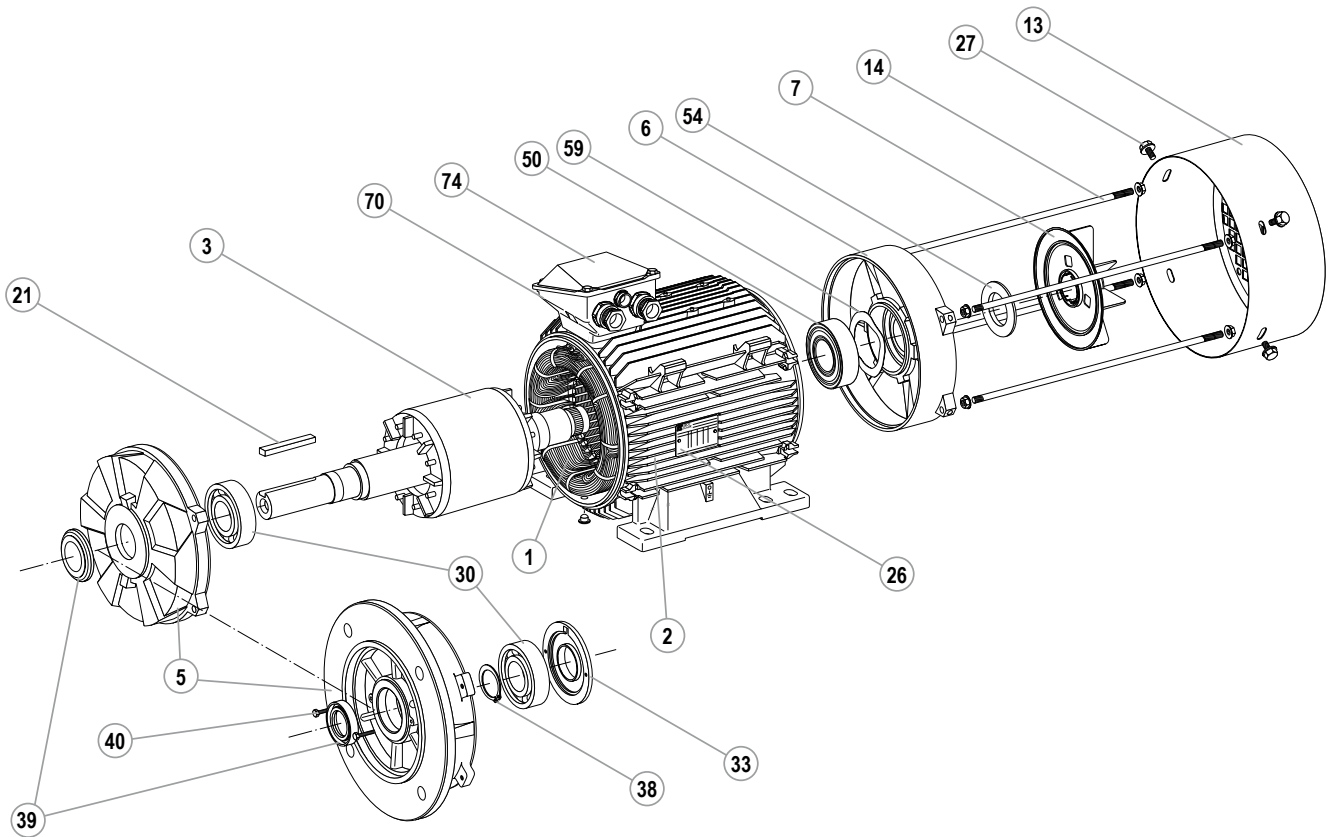

LSN 160 M/L, LSN 180 MT/LR

Item	Designation	Item	Designation	Item	Designation
1	Wound stator	14	Assembly rods	39	Coupling-side seal
2	Housing	21	Key	40	Cover fixing screws
3	Rotor	26	Nameplate	50	Rear bearing
5	Coupling-side flange	27	Cover fixing screw	54	Rear seal
6	Rear flange	30	Coupling-side bearing	59	Preload washer
7	Fan	33	Coupling-side internal cap	70	Terminal box body
13	Fan cover	38	Coupling-side bearing circlips	74	Terminal box cover

11.3 - LSN 180 L, LSN 200, LSN 225 ST/MT/MR, LSN 250 MZ motors

11.3.1 - Removal

- Remove the cover (13) once the screws (27) are removed;
- extract the fan (7) using a hub puller or failing this two diametrically opposite levers supported on the flange (6);
- remove the key (21) and withdraw the seals (39 and 54) for motors with feet, (39) for flanged motors;
- unscrew the assembly rods (14) then withdraw them;
- unscrew the fixing screws (40) of the inner cover (33);
- using a bronze drift, extract the flanges (5 and 6) by gently tapping on the flange pad; recover the pre-load washer (59);
- withdraw the circlips (38) if necessary;
- remove the rotor (3) from the stator (1) taking care not to touch the winding;
- extract the bearings (30) and (50) with a bearing puller whilst protecting the shaft end with a washer; avoid making contact with the shaft support surface.

11.3.2 - Re-fitting

- See § 10.2.4 before refitting;
- introduce the rotor front side inner cap (33) then refit the new bearings onto the shaft.
- fit the circlips (38) if necessary;
- introduce the rotor (3) into the stator (1) taking all precautions not to make contact with the winding;
- fit the pre-load washer (59) with a little grease in the bottom of the rear flange bearing cage (6), then refit the rear flange (6), positioning it on the stator;
- for fitting the cap (33), screw a threaded rod of the same diameter as the screws (40) into one of the threaded holes of the cap to ensure the correct angular positioning during refitting of the front flange (5); for a flange, fit a new seal (39) spring towards the exterior;
- refit the flange (5) taking care with the positioning of any cap;
- place the assembly rods in position (14) and tighten the nuts diagonally to the recommended torque (see § 10.2.4);
- fix the cap (33) with the screws (40);
- fit the new flange seals with grease (54) to the rear, (39) to the front for motors with feet;
- fit the fan (7) wedging it in place with a drift;
- check that the rotor turns freely by hand (and that there is no axial play if there is an immobilised bearing);
- refit the cover (13) and fix it in place with the screws (27);
- refit the key (21).

Bearings housings must be fitted with a front interior cap.

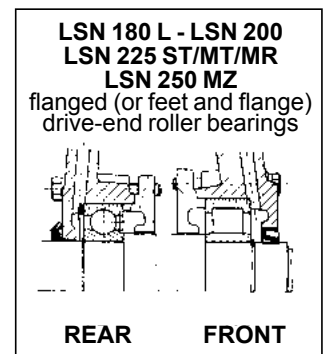
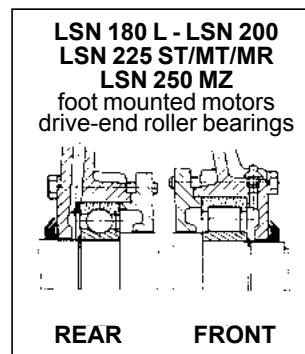
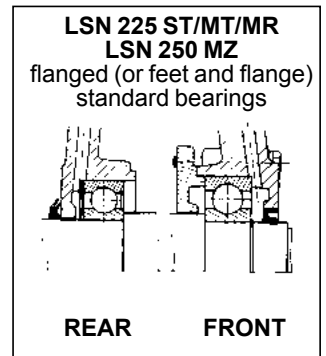
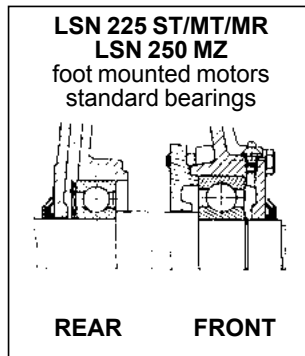
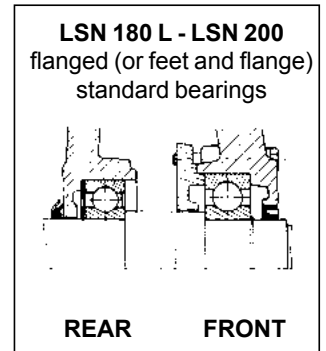
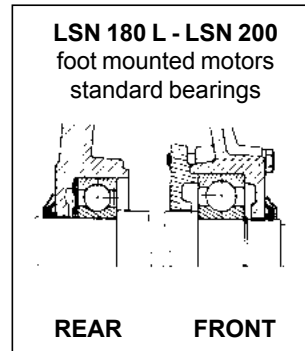

LSN 180 L, LSN 200, LSN 225 ST/MT/MR, LSN 250 MZ

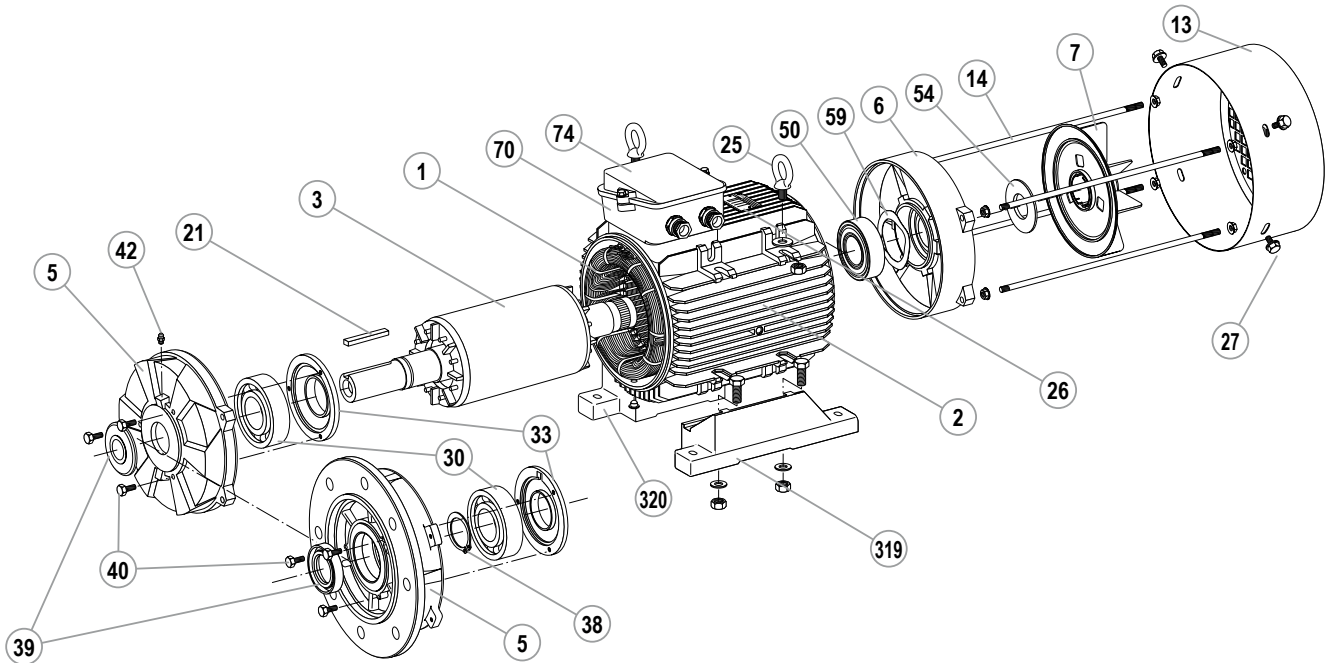

LSN 180 L, LSN 200, LSN 225 ST/MT/MR, LSN 250 MZ

Item	Designation	Item	Designation	Item	Designation
1	Wound stator	25	Lifting ring	50	Rear bearing
2	Housing	26	Nameplate	54	Rear seal
3	Rotor	27	Cover fixing screw	59	Preload washer
5	Coupling-side flange	30	Coupling-side bearing	70	Terminal box body
6	Rear flange	33	Coupling-side inner cap	74	Terminal box cover
7	Fan	38	Coupling-side bearing circlips	319	Right foot
13	Fan cover	39	Coupling-side seal	320	Left foot
14	Assembly rods	40	Cover fixing screws		
21	Key	42	Grease nipples (optional LSN 180 L, LSN 200)		

11.4 - LSN 250 ME, LSN 280 SC/MC motors

11.4.1 - Removal

- Remove the cover (13) once the screws (27) are removed;
- extract the fan (7) using a hub puller or failing this two diametrically opposite levers supported on the flange (6);
- remove the key (21) and withdraw the seals (39) and (54) ;
- unscrew the flange fixing screws (270) and (273) ;
- unscrew the fixing screws (40) of the inner cover (33);
- using a bronze drift, extract the flanges (5 et 6) by gently tapping on the flange pad; recover the pre-load washer (59);
- withdraw the circlips (38);
- remove the rotor (3) from the stator (1) taking care not to touch the winding;
- extract the bearings (30) and (50) with a bearing puller whilst protecting the shaft end with a washer; avoid making contact with shaft support surface.

11.4.2 - Re-fitting

- See § 10.2.4 before refitting;
- introduce the rotor front side inner cap (33) then refit the new bearings onto the shaft.
- fit the circlips (38);
- introduce the rotor (3) into the stator (1) taking all precautions not to make contact with the winding;
- when fitting the cap (53), screw a threaded rod of the same diameter as the screws (62) into one of the threaded holes of the cap to ensure the correct angular positioning during refitting of the rear flange (6);
- fit the pre-load washer (59) with a little grease in the bottom of the rear flange bearing cage (6), then refit the rear flange (6), positioning it on the stator;
- fix the cap (53) with the screws (62);
- when fitting the cap (33), screw a threaded rod of the same diameter as the screws (40) into one of the threaded holes of the cap to ensure the correct angular positioning during refitting of the front flange (5); fit a new seal (39);
- refit the flange (5) taking care with the positioning of the cap;
- place the fitting screws in position (270) and (273) and tighten them diagonally to the recommended torque (see § 10.2.4);
- when fitting the cap (53), screw a threaded rod of the same diameter as the screws (62) into one of the threaded holes of the cap to ensure the correct angular positioning during refitting of the rear flange (6);
- fix the cap (33) with the screws (40);
- fit the flange seals with grease (54 to the rear, 39 to the front for motors with feet);
- fit the fan (7) wedging it in place with a drift;
- check that the rotor turns freely by hand (and that there is no axial play if there is an immobilised bearing);
- refit the cover (13) and fix it in place with the screws (27);
- refit the key (21).

Bearings housings must be fitted with a front interior cap.

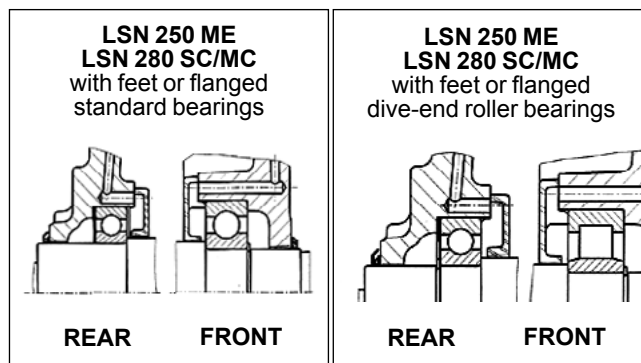

LSN 250 ME, LSN 280 SC/MC

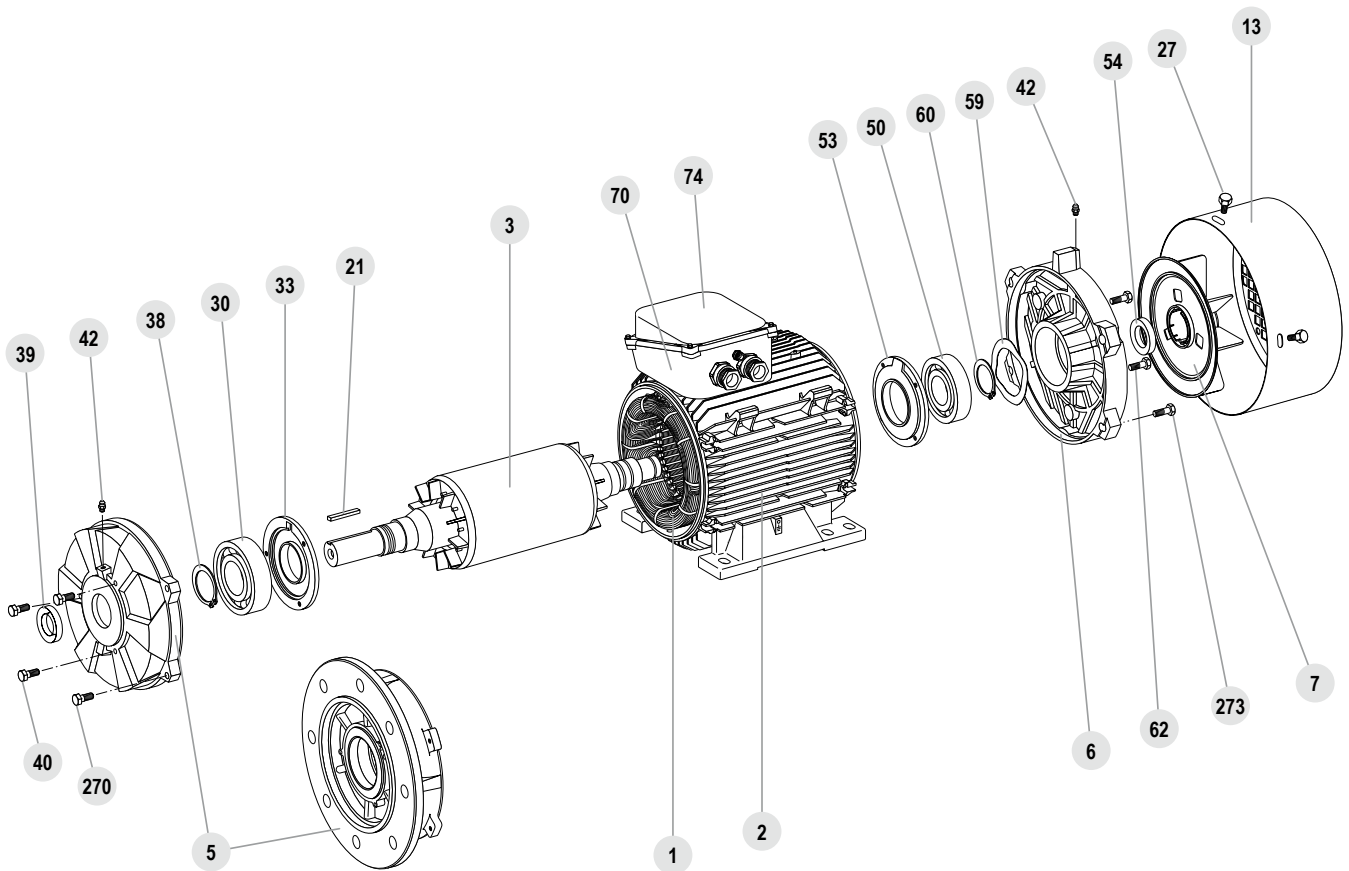

LSN 250 ME, LSN 280 SC/MC

Item	Designation	Item	Designation	Item	Designation
1	Wound stator	30	Coupling-side bearing	59	Preload washer
2	Housing	33	Coupling-side internal cover	60	Rear bearing circlips
3	Rotor	38	Coupling-side bearing circlips	62	Cover fixing screws
5	Coupling-side flange	39	Coupling-side seal	70	Terminal box body
6	Rear flange	40	Cover fixing screws	74	Terminal box cover
7	Fan	42	Grease nipples	270	Coupling-side flange fixing screw
13	Fan cover	50	Rear bearing	273	Rear flange fixing screw
21	Shaft end key	53	Rear inner cap		
27	Cover fixing screw	54	Rear seal		

11.5 - LSN 280 SD/MD, LSN 315 motors

11.5.1 - Removal

- Remove the cover (13) once the screws (27), grease nipple (42) and its extension have been removed;
- extract the fan (7) using a hub puller or failing this two diametrically opposite levers supported on the flange (6); for aluminium fans heat the fan hub to about 100°C before extracting it;
- remove the key (21);
- unscrew the assembly rods (14) then withdraw them;
- unscrew the fixing screws (40) at the front of the inner cap (33) and at the rear the fixing screws (62) of the caps (32) and (52), withdraw the caps;
- unscrew the “CHc” screws of the mobile valves (35 and 56) then unscrew the valves using a hook spanner or a tapered bronze drift; unscrew the valves by hand and remove them. The valves hold the seals (39 and 54);
- withdraw the fixed valves (34 and 35) from the bearing housing;
- using a bronze drift, extract the flanges (5 et 6) by gently tapping on the flange pad;
- check that the cap (53) has a diameter less than that of the stator, if not extract the bearing (50) in accordance with the instructions below;
- remove the rotor (3) from the stator (1) front side taking care not to touch the winding with the inner cap if there is no internal turbine. Extract the bearings (30) and (50) with a bearing puller whilst protecting the shaft extension end with a washer; avoid making contact with the shaft seating.
- the bearings are extracted either on their own or with the caps (33 and 53); in order not to deform the caps, heat the bearing outer ring with a flame, (the bearing is to be scrapped).
- recover the pre-load washer or springs (59) in the cap (53).

11.5.2 - Re-fitting

- See & 5.1 before refitting.
- introduce the inner cap (33) front side of the rotor and the inner cap (53) rear side, not forgetting to fit the pre-load washers (59);
- apply new grease: the bearings housing must be filled to 50% of the free volume with new grease;
- refit the new bearings (30 et 50) on the shaft, see § 5.3 fitting the bearings;
- introduce the rotor (3) into the stator (1) taking all precautions not to make contact with the winding;
- screw in a threaded rod of the same diameter as the screws (40) and (62) into one of the threaded holes of the caps (33) and (53) to ensure positioning of the grease nipple hole when refitting the flanges (5 and 6);
- check that the pre-load springs are correctly installed;
- fit the flange (6) rear side, positioning it on the stator, then fit the fixed valve (55) in the housing of the flange;
- fit the mobile valve (56) screwing it in or immobilising it, taking care that the seal (54) has been correctly installed on the valve.

- fit the external cap (52) using cap locking screws (62) taking care that the grease removal hole is at the bottom point;
- fit the flange (5) front rear, positioning it on the stator then fit the fixed valve (34) in the housing of the flange;
- fit the mobile valve (35) screwing it in or immobilising it, taking care that the seal (39) has been correctly installed on the valve;
- fit the external cap (32) using the cap locking screws (40) taking care that the grease removal hole is at the bottom point;
- fit the assembly rods in place (14) not forgetting the cover feet (380), tighten the nuts diagonally without fully locking them, in order to be able to position the cover feet when it is fitted;
- fit the fan (7) wedging it in place with a drift or by heating the aluminium fan hub to around 100°C;
- check that the motor turns freely by hand and that there is no axial play;
- refit the cover (13) fixing it using the screws (27), refit the grease nipple (42) and its extension in place;
- re-tighten the rod nuts (14) diagonally at all times to the torque recommended in § 5.1 ;
- refit the key (21).

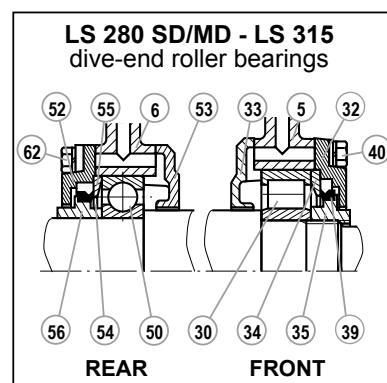
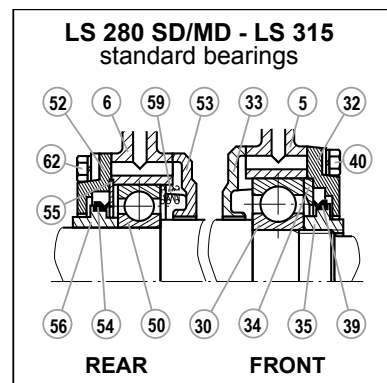

LSN 280 SD/MD, LSN 315

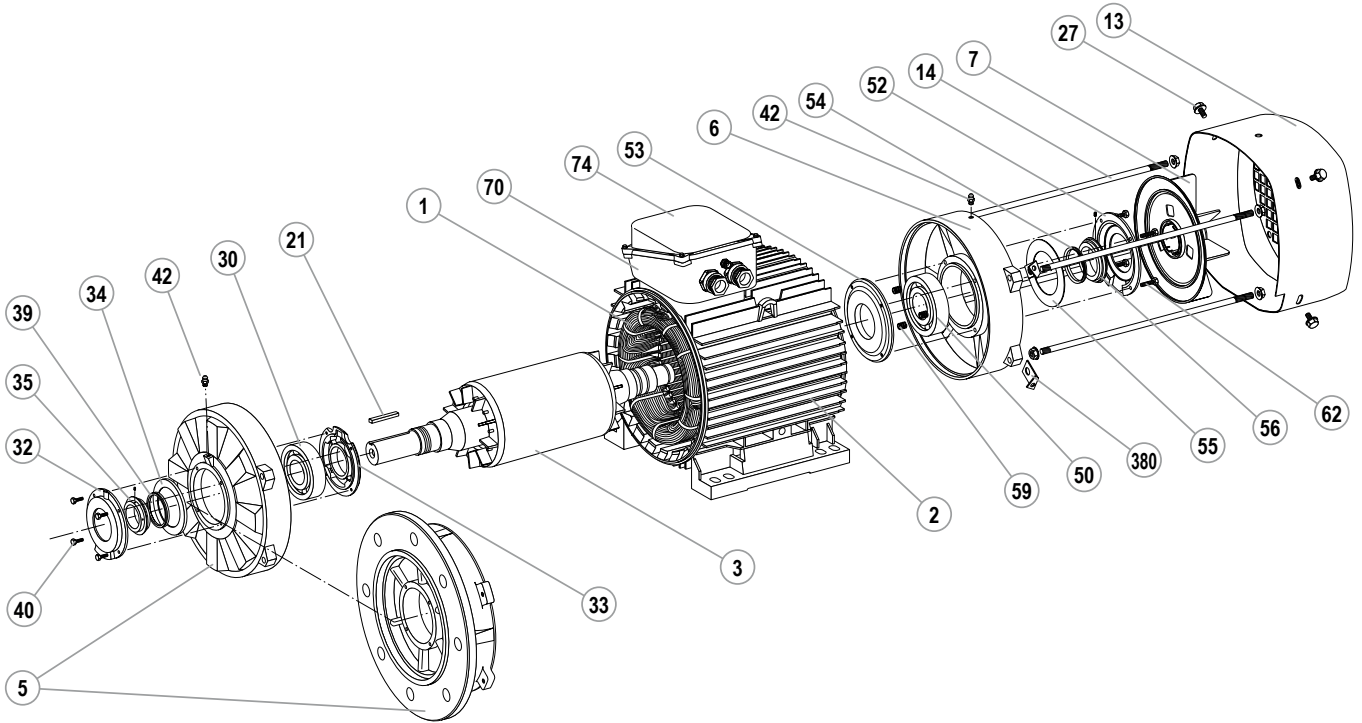

LSN 280 SD/MD, LSN 315

Item	Designation	Item	Designation	Item	Designation
1	Wound stator	30	Coupling-side bearing	53	Rear inner cap
2	Housing	32	Coupling-side outer cap	54	Rear seal
3	Rotor	33	Coupling-side inner cap	55	Rear fixed grease valve
5	Coupling-side flange	34	Coupling-side fixed grease valve	56	Rear mobile grease valve
6	Rear flange	35	Coupling-side mobile grease valve	59	Pre load spring or washer
7	Fan	39	Coupling-side seal	62	Cover fixing screws
13	Fan cover	40	Cover fixing screws	70	Terminal box body
14	Assembly rods	42	Grease nipples	74	Terminal box cover
21	Key	50	Rear bearing	380	Cover feet
27	Cover fixing screw	52	Rear outer cap		

12 - FLSN MOTORS

12.1 - FLSN 160 and 180 motors

12.1.1 - Removing the rear bearing housing

- Remove the cover (13) once the fixing screws (27) have been removed;
- extract the fan (7);
- withdraw the fixing screws (273) from the rear bearing housing (6);
- using two levers or a soft hammer, release the rear bearing housing (6), keeping the latter straight. Release the bearing housing by sliding it on the shaft. The seal (54) follows and is not re-usable;
- recover the pre-load washer (59) which is to be relocated in its housing.

12.1.2 - Removing the front bearing housing

- Withdraw the fixing screws (270) from the front bearing housing;
- using a suitable lifting device, extract the rotor (3) + front bearing housing (5) assembly, without making contact with the winding;
- withdraw the fixing screws (40) of the front inner cover (33);
- release the key (21);
- using two levers or a soft hammer, separate the front bearing housing (5) from the rotor (3), keeping the latter straight;
- release the bearing housing by sliding it on the shaft. The seal (39) follows and is not re-usable.

12.1.3 - Changing the bearings

- Extract the bearings (30) and (50) using a suitable tool whilst protecting the end of the shaft extension. Avoid making contact with the shaft support surface;
- change the bearings (hot fitting only).

12.1.4 - Re-fitting

- Fit the bearings on the rotor shaft (do not forget the front inner cover (33));
- slide the front bearing housing (5) over the bearing (30);
- re-fit the fixing screws (40) of the inner cover (33);
- introduce the rotor + bearing housing assembly into the stator without making contact with the winding;
- present the bearing housings, grease nipples upwards, not forgetting the pre load washer (59) to the rear. Slide them until they are fully engaged;
- engage the bearing housings;
- check that the motor turns freely by hand.

FROM this point on we recommend that at every step you check that the motor rotates freely by hand before moving on to the next instruction.

- refit the bearing housing fixing screws (270) and (273);
- refit a new seal (54) in position using a drift;
- replace the fan (7);
- replace the cover (13) and refit the fixing screws (27);
- refit the new seal (39) in position using a drift;
- grease the front and rear bearings whilst rotating the shaft by hand.

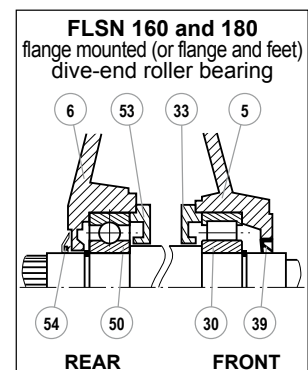
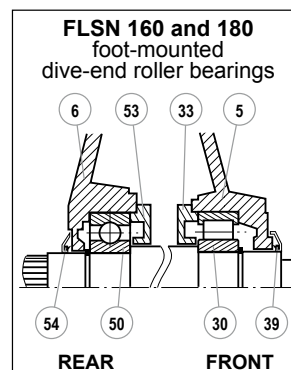
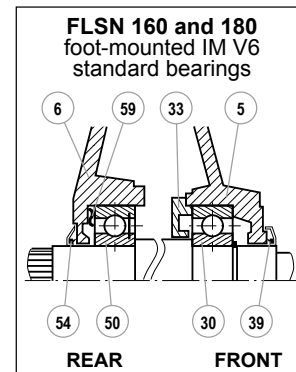
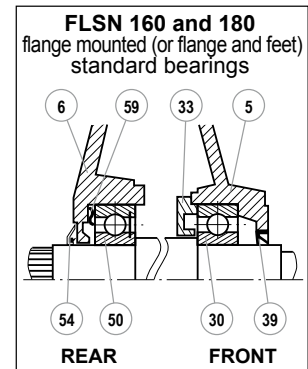
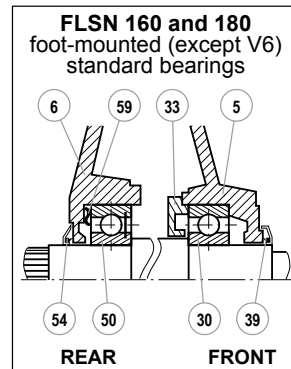

FLSN 160 and 180

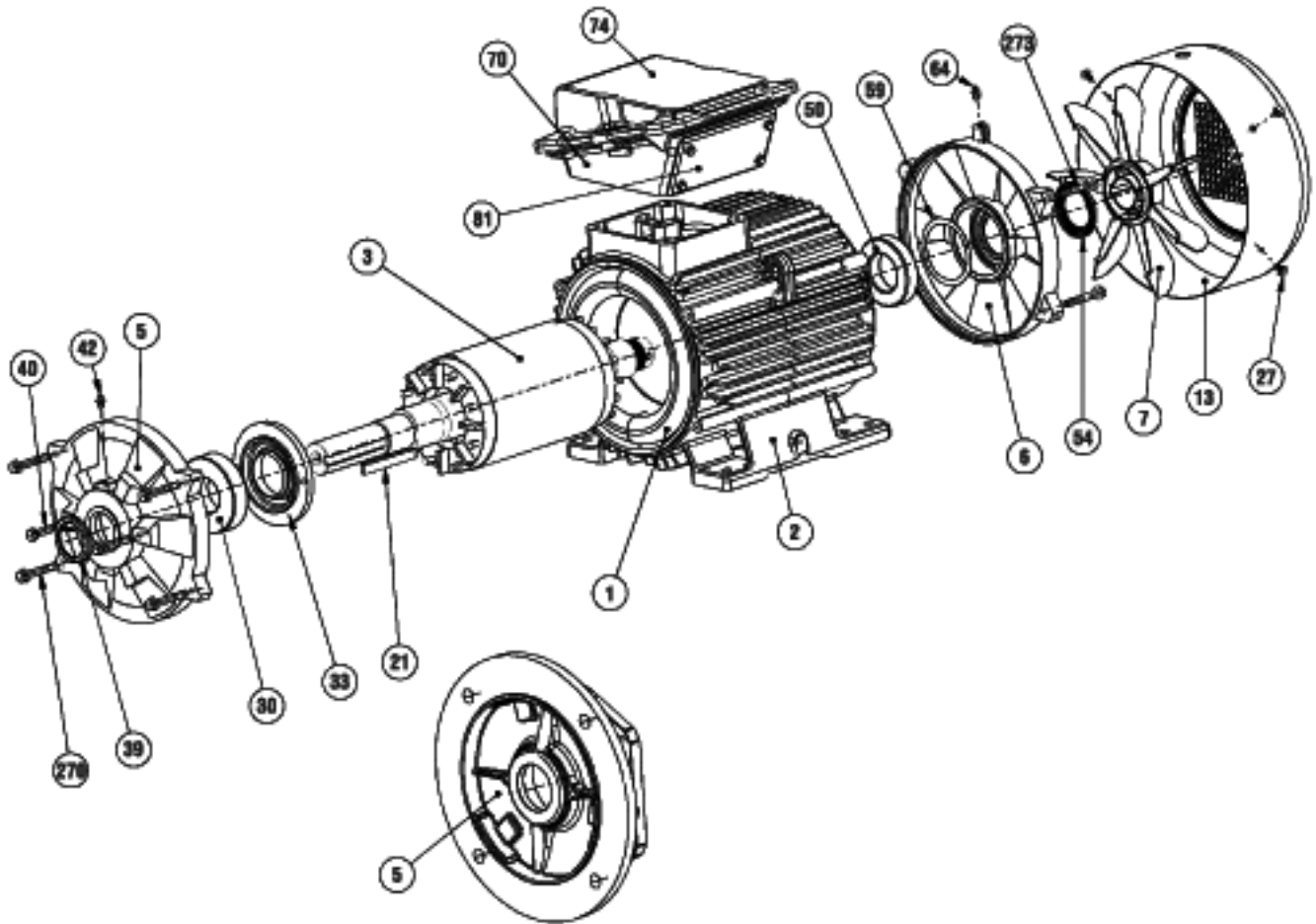

FLSN 160 and 180

Item	Designation	Item	Designation	Item	Designation
1	Wound stator	27	Cover fixing screw	59	Rear preload washer
2	Frame	30	Coupling-side bearing	64	Rear grease nipple
3	Rotor	33	Front inner cover	70	Stator terminal box body
5	Coupling-side flange	39	Front lip seal	74	Terminal box cover
6	Rear flange	40	Cover fixing screws	81	Cable gland support plate
7	Fan	42	Front grease nipple	270	Front flange fixing screw
13	Fan cover	50	Rear bearing	273	Rear flange fixing screw
21	Shaft end key	54	Rear lip seal		

12.2 - FLSN 200 to 225 ST motors

12.2.1 - Removing the rear bearing housing

- Remove the cover (13) once the fixing screws (27) have been removed;
- extract the fan (7);
- withdraw the fixing screws of the rear inner cover (53);
- withdraw the fixing screws (273) from the rear bearing housing (6);
- using two levers or a soft hammer, release the rear bearing housing (6), keeping the latter straight. Release the bearing housing by sliding it on the shaft. The seal (54) follows and is not re-usable.
- put the dismantled components to one side and recover the pre-load washer (59) which is to be relocated in its housing.

12.2.2 - Removing the front bearing housing

- Remove the front bearing housing without releasing the rotor (3). To do this:
- withdraw the fixing screws (40) of the front inner cover (33);
- withdraw the fixing screws (270) from the front bearing housing (5);
- withdraw the fixing screws of the front inner cover (33);
- release the key (21);
- using two levers or a soft hammer, extract the rear bearing cover (5), keeping the latter straight;
- release the bearing housing by sliding it on the shaft. The seal (39) follows and is not re-usable.

12.2.3 - Changing the bearings

- using a suitable lifting device, extract the rotor without making contact with the winding;
- extract the bearings (30) and (50) using a suitable tool whilst protecting the end of the shaft extension. Avoid making contact with the shaft support surface;
- the mobile parts of the grease valve (35) for the front and (56) for the rear follow;
- put to one side the components (55) - (56) for the rear and (34) - (35) for the front;
- change the bearings (hot fitting only)

12.2.4 - Re-fitting

- Fit the front bearing (30) on the rotor shaft (do not forget the inner cover (33), as well as the rear bearing (50) if and only if the inner \varnothing of the stator allows the rear inner cover (53) to pass through;
- fit in place the fixed part of the grease valves (item (55) for the rear and (34) for the front);
- hot-fit the mobile part of the grease valves (item (56) for the rear and (35) for the front). Check that it rests on the inner ring of the bearing;
- introduce the rotor into the stator taking care not to make contact with the winding. Put the rear bearing in place if this has not already been done.
- present the bearing housings, grease nipples upwards. Start with the front bearing housing (5). Fit a pin in one of the inner cover (33) threaded holes **to align the grease feed pipes**. Slide it until they are fully fitted.
- finish with the rear bearing housing (6). Fit a pin in one of the inner cover (53) threaded holes **to align the grease feed pipes**;
- lift the rotor slightly and fit the bearing housing on the frame.

From this point on we recommend that at every step you check that the motor rotates freely by hand before moving on to the next instruction.

- refit the bearing housing fixing screws (270) and (273);
- refit the inner cover fixing screws (33) and (53);
- refit a new seal (54) in position using a drift;
- replace the fan (7);
- refit a new seal (39) in position using a drift;
- replace the cover (13) and refit the fixing screws (27);
- grease the front and rear bearings whilst rotating the shaft by hand.

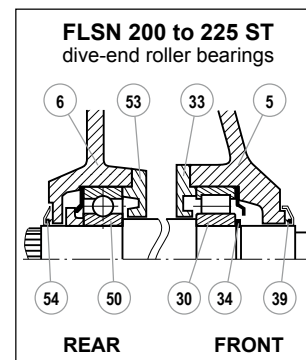
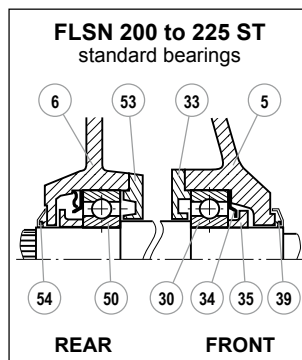

FLSN 200 to 225 ST

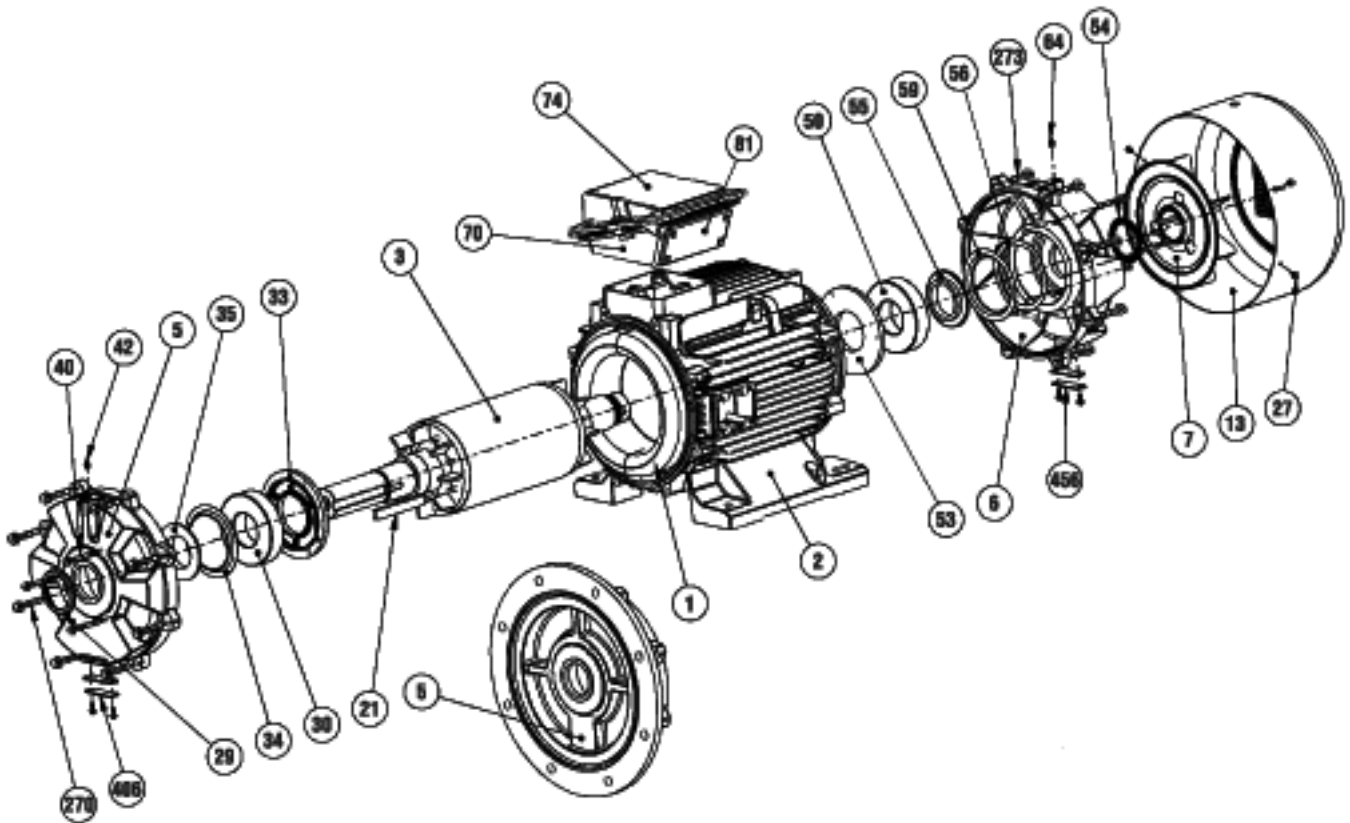

FLSN 200 to 225 ST

Item	Designation	Item	Designation	Item	Designation
1	Wound stator	33	Front inner cover	56	Mobile part of the rear grease valve
2	Frame	34	Fixed part of the front grease valve	59	Rear preload washer
3	Rotor	35	Mobile part of the front grease valve	64	Rear grease nipple
5	Coupling-side flange	39	Front lip seal	70	Stator terminal box body
6	Rear flange	40	Cover fixing screws	74	Stator terminal box cover
7	Fan	42	Front grease nipple	81	Cable gland support plate
13	Fan cover	50	Rear bearing	270	Front flange fixing screw
21	Shaft end key	53	Rear inner cover	273	Rear flange fixing screw
27	Cover fixing screw	54	Rear lip seal	406	Front grease valve closure plate
30	Coupling-side bearing	55	Fixed part of the rear grease valve	456	Rear grease valve closure plate

12.3 - FLSN 225 M to 280 motors

12.3.1 - Removing the rear bearing housing

- Remove the cover (13) once the fixing screws (27) have been removed;
- remove the shaft extension screw if necessary;
- extract the fan (7);
- withdraw the fixing screws of the rear inner cover (53);
- withdraw the fixing screws (273) from the rear bearing housing (6);
- remove the fan key if relevant;
- using two levers or a soft hammer, release the rear bearing housing (6), keeping the latter straight. Release the bearing housing by sliding it on the shaft;
- put the dismantled components to one side and recover the pre-load washer (59) which is to be relocated in its housing.

12.3.2 - Removing the front bearing housing

- Remove the front bearing housing without releasing the rotor (3). To do this:
- withdraw the fixing screws (270) from the front bearing housing (5);
- withdraw the fixing screws (40) of the front inner cover (33);
- release the key (21);
- using two levers or a soft hammer, extract the rear bearing cover (5), keeping the latter straight;
- release the bearing housing by sliding it on the shaft.

12.3.3 - Changing the bearings

- using a suitable lifting device, extract the rotor without making contact with the winding;
- remove the front circlips (38);
- extract the bearings (30) and (50) using a suitable tool whilst protecting the end of the shaft extension. Avoid making contact with the shaft support surface;
- change the bearings (hot fitting only).

12.3.4 - Re-fitting

- Fit the front bearing (30) on the rotor shaft (do not forget the inner cover (33) and the circlips (38), as well as the rear bearing (50) if and only if the inner \varnothing of the stator allows the rear inner cover (53) to pass through;
- introduce the rotor into the stator taking care not to make contact with the winding. Put the rear bearing in place if this has not already been done.
- fill the decompression grooves (416) located in the shaft passage with grease;
- present the bearing housings, grease nipples upwards. Start with the front bearing housing (5). Fit a pin in one of the inner cover (33) threaded holes **to align the grease feed pipes**.
- finish with the rear bearing housing (6). Fit a pin in one of the inner cover (53) threaded holes **to align the grease feed pipes**.
- lift the rotor slightly and locate the bearing housings.

From this point on we recommend that at every step you check that the motor rotates freely by hand before moving on to the next instruction.

- refit the bearing housing fixing screws (270) and (273);
- fit the inner cover fixing screws (33) and (53). Replace the AZ washers to ensure a perfect seal.
- refit the fan key if relevant;
- replace the fan (7);
- replace the shaft extension screw if necessary;
- replace the cover (13) and refit the fixing screws (27);
- grease the front and rear bearings whilst rotating the shaft by hand.

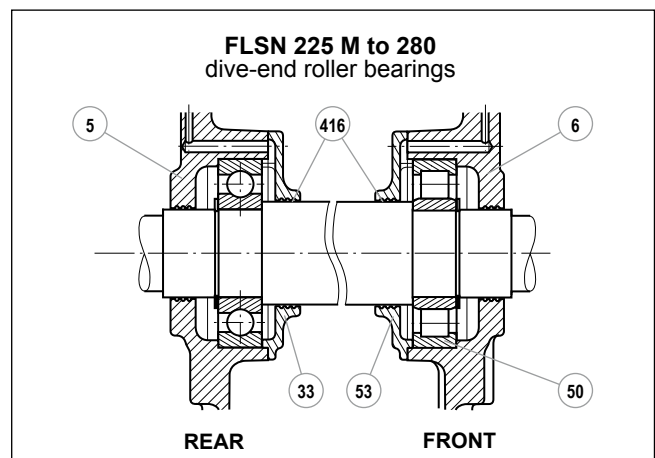
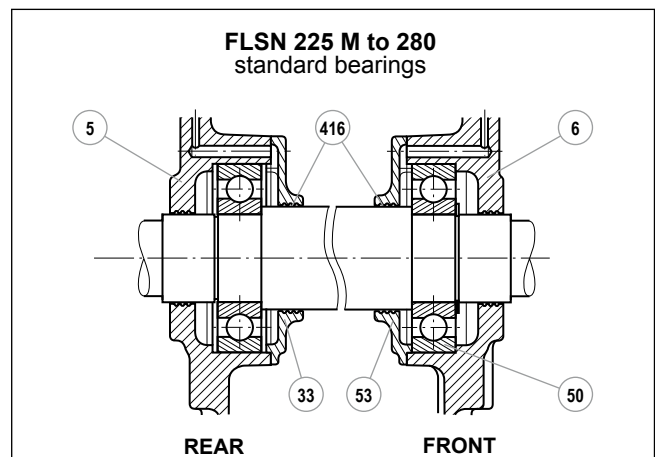

FLSN 225 M to 280

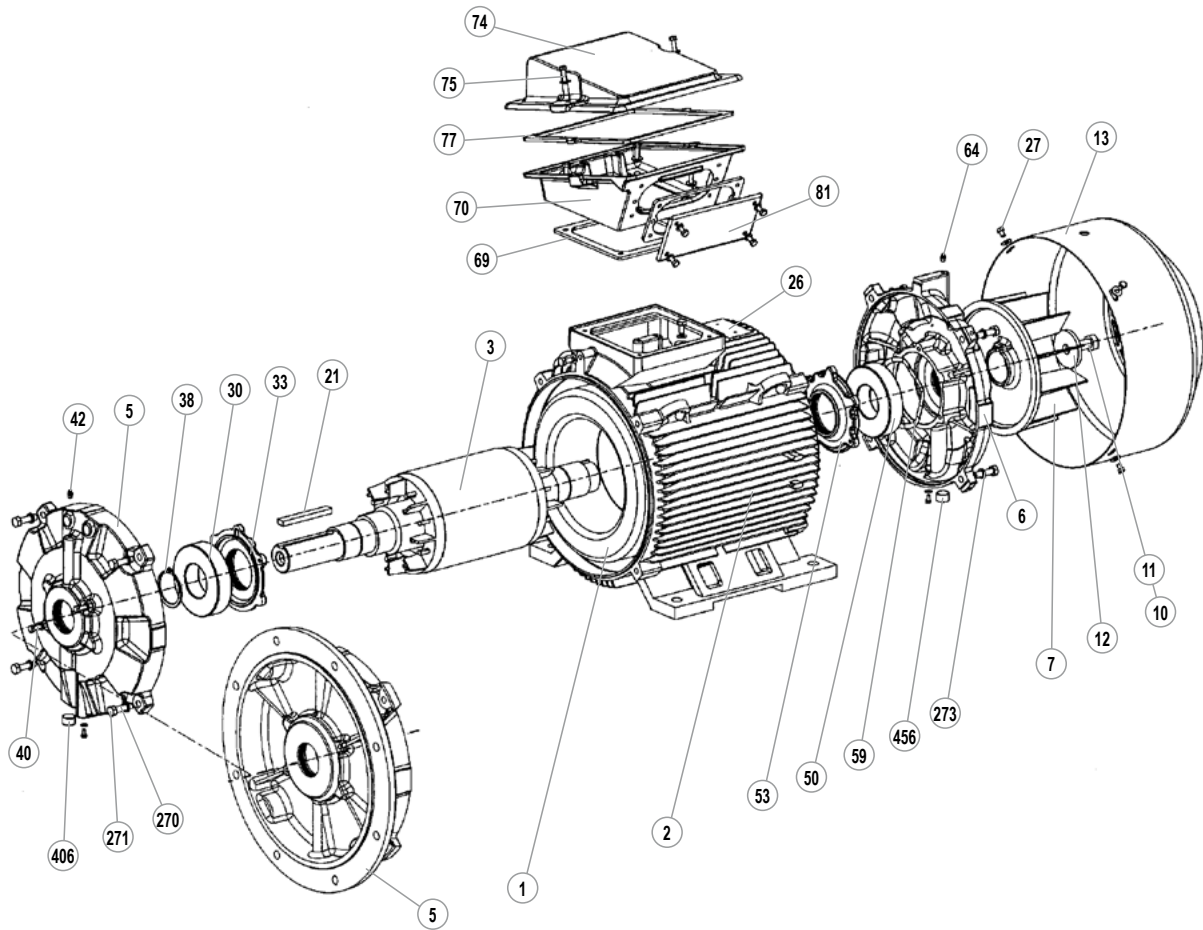

FLSN 225 M to 280

Item	Designation	Item	Designation	Item	Designation
1	Wound stator	26	Nameplate	69	Terminal box base seal
2	Frame	27	Cover fixing screw	70	Stator terminal box body
3	Rotor	30	Coupling-side bearing	74	Stator terminal box cover
5	Coupling-side flange	33	Front inner cover	75	Terminal box cover fastening screws
6	Rear flange	38	Front bearing circlips	77	Terminal box cover seal
7	Fan	40	Cover fixing screws	81	Cable gland support plate
10	Fan or turbine screw (280 - 4p)	42	Front grease nipple	270	Front flange fixing screw
11	Lock washer (not shown) (280 - 4p)	50	Rear bearing	271	Front flange fixing nut
12	Lock washer (280 - 4p)	53	Rear inner cover	273	Rear flange fixing screw
13	Fan cover	59	Rear preload washer	406	Grease valve closure plate front - (plug)
21	Shaft end key	64	Rear grease nipple	456	Grease valve closure plate rear - (plug)

12.4 - FLSN 315 S to 355 LD motors

12.4.1 - Removing the rear bearing housing

- Withdraw the grease nipple extension (65);
- remove the cover (13) once the fixing screws (27) have been removed;
- remove the shaft extension screws and washer;
- extract the fan (7);
- extract the key from the fan (not shown);
- withdraw the fixing screws of the rear inner cover (53);
- withdraw the fixing screws (273) from the rear bearing housing (6);
- using two levers or a soft hammer, release the rear bearing housing (6). Release and hold the bearing housing by sliding it on the shaft;
- put the dismantled components to one side.

12.4.2 - Removing the front bearing housing

- Remove the front bearing housing without releasing the rotor (3). To do this:
- release the key (21);
- withdraw the fixing screws of the front inner cover (33);
- withdraw the fixing screws (270) from the front bearing housing;
- using two levers or a soft hammer, extract the rear bearing cover (5), keeping the latter straight;
- release the bearing housing by sliding it on the shaft;
- put the dismantled components to one side.

12.4.3 - Changing the bearings

- using a suitable lifting device, extract the rotor without making contact with the winding;
- extract the bearings (30) and (50) using a suitable tool whilst protecting the end of the shaft extension. Avoid making contact with the shaft support surfaces.
- change the bearings (hot fitting only).

12.4.4 - Re-fitting

- Fit the front bearing (30) on the rotor shaft (do not forget the inner cover (33) as well as the rear bearing (50) and the inner cover (53);
- introduce the rotor into the stator taking care not to make contact with the winding;
- do not forget to refit the pre load washers in their housing;
- start with the held bearing housing (see above). Fit a pin in one of the inner cover threaded holes **to align the grease feed pipes.**
- finish with the non-held bearing housing. Fit a pin in one of the inner cover threaded holes **to align the grease feed pipes.**
- lift the rotor slightly and locate the bearing housings.

From this point on we recommend that at every step you check that the motor rotates freely by hand before moving on to the next instruction.

- refit the bearing housing fixing screws (270) and (273);
- refit the inner cover fixing screws (33) and (53);
- refit the fan (7) fitted with its key;
- refit the shaft extension screw with its washer;
- refit the cover (13);
- grease the front and rear bearings.

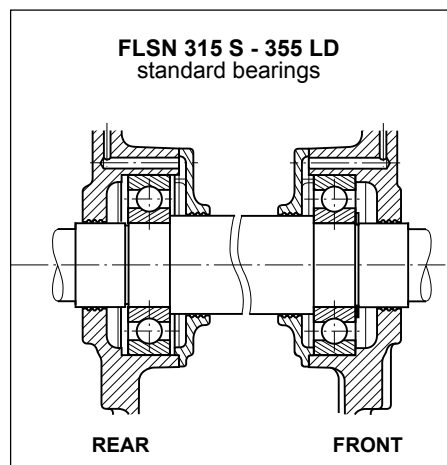

FLSN 315 S to 355 LD

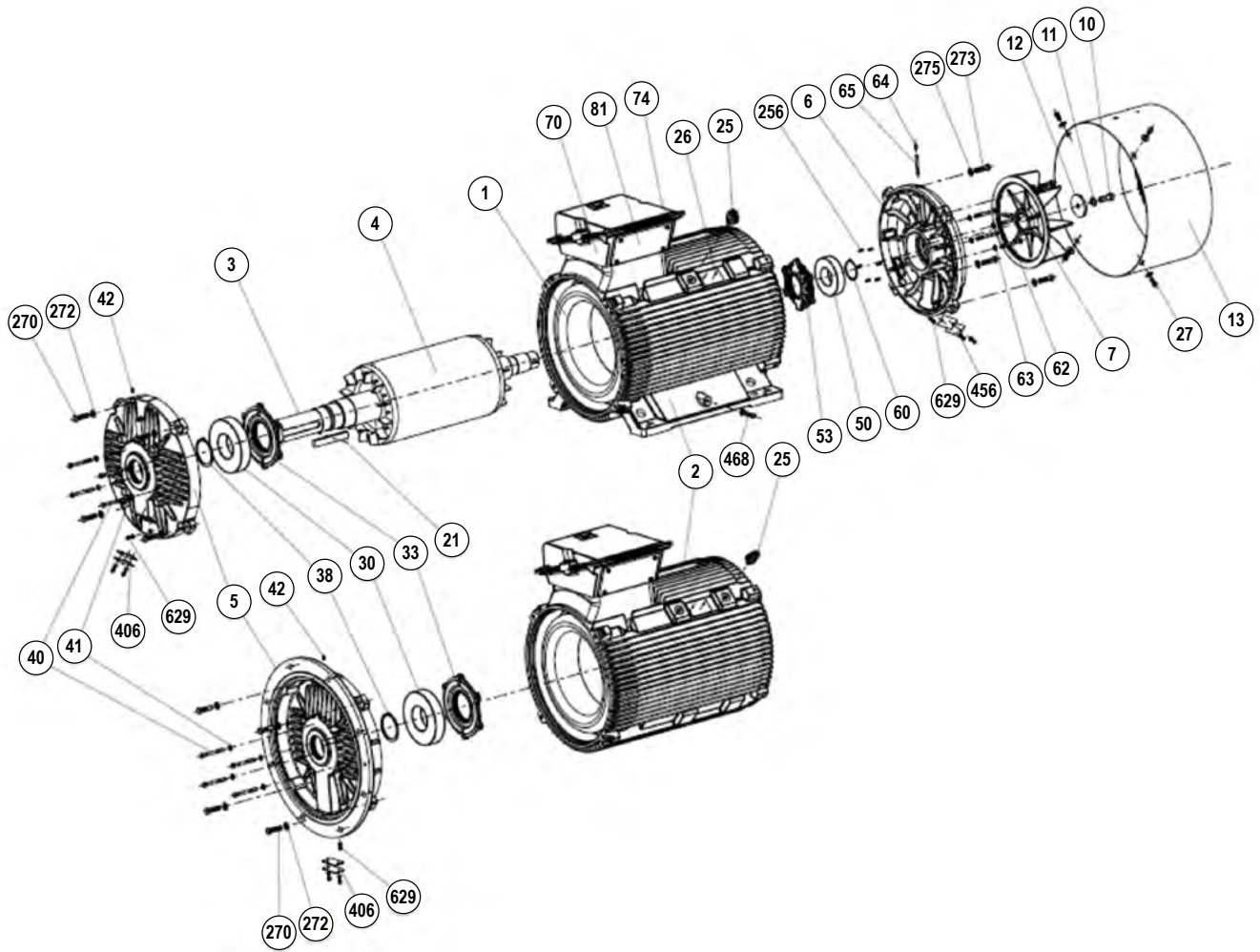

FLSN 315 S to 355 LD

Item	Designation	Item	Designation	Item	Designation
1	Wound stator	27	Cover fixing screw	70	Stator terminal box body
2	Frame	30	Coupling-side bearing	74	Stator terminal box cover
3	Shaft	33	Coupling-side inner cap	81	Cable gland support plate
4	Rotor	38	Elastic ring for coupling-side shaft	256	Preload washer
5	Coupling-side flange	40	Coupling-side cap fixing screw	270	Coupling-side flange fixing screw
6	Flange opposite coupling-side	41	Coupling-side cap sealed toothed washer	272	Coupling-side flange fixing washer
7	Fan	42	Front grease nipple	273	Flange opposite coupling-side fixing screw
10	Fan or turbine screw	50	Bearing opposite coupling-side	275	Flange fixing washer opposite coupling-side
11	Lock washer	53	Cap opposite coupling-side	406	Front grease valve closure plate
12	Lock washer	60	Retaining ring	456	Rear grease valve closure plate
13	Fan cover	62	Cover fixing screws	468	Earth terminal screw
21	Coupling-side shaft extension key	63	Cap fixing washer opposite coupling-side	629	Drain plug
25	Lifting ring	64	Rear grease nipple		
26	Nameplate	65	Rear grease nipple extension		

12.5 - FLSN 355 LK to 450 motors

12.5.1 - Removing the rear bearing housing

- Withdraw the grease nipple extension (65);
- remove the cover (13) once the fixing screws (27) have been removed. There is a threaded hole into which a lifting ring may be screwed to facilitate separation.
- remove the fan fixing screw and washer (10 -12) and the lock washer (11);
- extract the fan (7);
- extract the fan key (not shown) and the mobile part of the grease valve (56);
- withdraw the fixing screws of the rear inner cover (53);
- withdraw the fixing screws from the rear bearing housing (273);
- using two levers separate the rear bearing housing (6). Screw in a lifting ring instead of one of the cover fixing screws. Align the bearing housing to bring the ring upwards. Release the bearing housing with a hoist by sliding it on the shaft.

12.5.2 - Removing the front bearing housing

- Remove the front bearing housing without releasing the rotor (3). To do this:
 - release the key (21);
 - heat the mobile part of the front valve (35). Unscrew it and remove it.
 - withdraw the fixing screws of the front inner cover (33);
 - withdraw the fixing screws (270) from the front bearing housing;
 - using two levers or a soft hammer, extract the rear bearing housing (5), keeping the latter straight;
 - release the bearing housing by sliding it on the shaft;
 - put the dismantled components to one side and recover the mobile part of the front grease valve (35) which is to be relocated in its housing.

12.5.3 - Changing the bearings

- The operation can be carried out without removing the rotor;
- move the inner covers (53) and (33) back so as to facilitate fitting the bearing extraction tool. Extract the bearings.

12.5.4 - Re-fitting

- Fit the front (30) and rear (50) bearings on the rotor shaft;
- do not forget to refit the pre load washers (59) in their housing;
- start with the rear bearing housing (6). Fit a pin in one of the inner cover (53) threaded holes to align the grease feed pipes.
- finish with the front bearing housing (5). Fit a pin in one of the inner cover (33) threaded holes to align the grease feed pipes.
- engage the bearing housing on the bearing. Align it so as to bring the grease nipple uppermost.
- slide it until it is fully fitted;
- lift the rotor slightly and fit the bearing housings on the frame;

- refit the bearing housing fixing screws;
- refit the cover fixing screws;
- refit the mobile part of the grease valve;
- refit the fan (7) fitted with its key;
- refit the shaft extension screw with its washers (10) (11) (12);
- refit the cover;
- refit the front grease nipple extension (65);
- coat the thread of the front grease valve mobile part (35) with weak thread-lock compound. Re-tighten it.
- grease the front and rear bearings.

Note: Release of the rotor if necessary

- Place 1 strap at each end of the rotor. Lift it using a hoist until it is no longer resting on the stator. Push it as far to the rear as you can. Reposition the rotor and replace the straps in order to repeat the operation as many times as necessary.
- when you can no longer fix the front strap (rotor engaged too far in the stator), keep the rear strap;
- lift slightly, engage a hollow bar onto the shaft and lever it to compensate for the weight of the rotor;
- release the rotor.

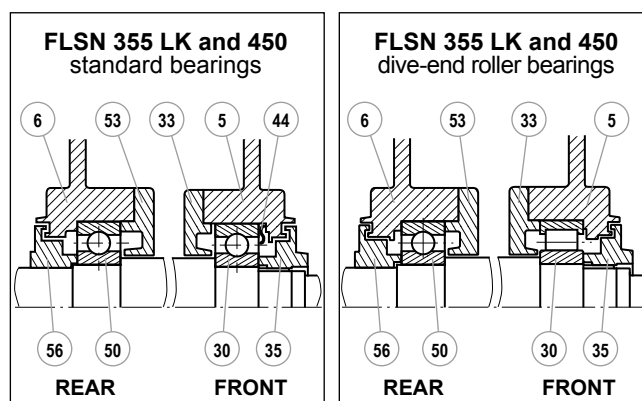

FLSN 355 LK to 450

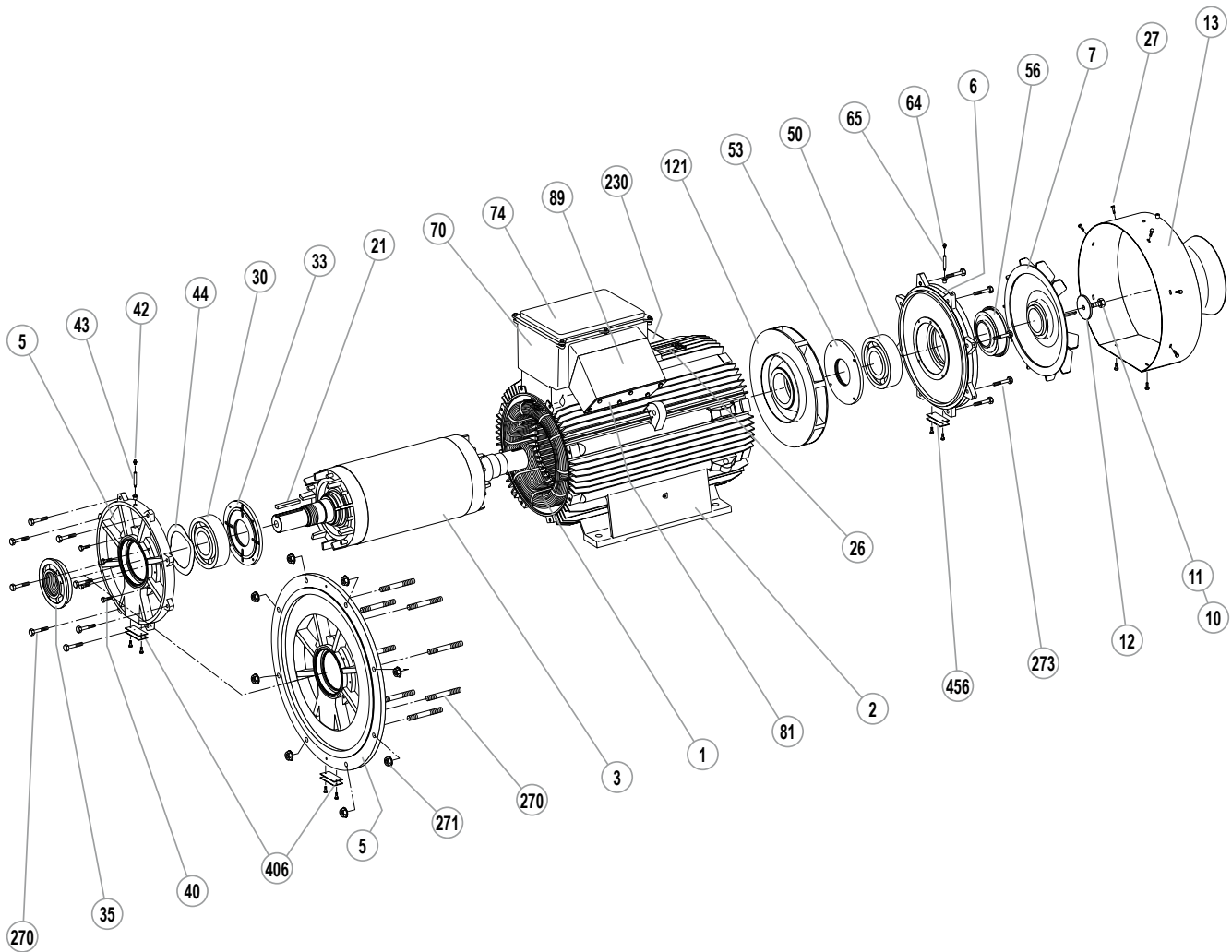

FLSN 355 LK to 450

Item	Designation	Item	Designation	Item	Designation
1	Wound stator	27	Cover fixing screw	65	Rear grease nipple extension
2	Frame	30	Coupling-side bearing	70	Stator terminal box body
3	Rotor	33	Front inner cover	74	Stator terminal box cover
5	Coupling-side flange	35	Mobile part of the front grease valve	81	Cable gland support plate
6	Rear flange	40	Cover fixing screws	89	Connector - terminal box flare
7	Fan	42	Front grease nipple	121	Mixer
10	Fan or turbine screw	43	Front grease nipple extension	230	Auxiliary terminal box (from 355 LK to 450)
11	Lock washer (not shown)	44	Front preload washer	270	Front flange fixing screw
12	Lock washer	50	Rear bearing	271	Rear flange fixing nut
13	Fan cover	53	Rear inner cover	273	Rear flange fixing screw
21	Shaft end key	56	Mobile part of the rear grease valve	406	Front grease valve closure plate
26	Nameplate	64	Rear grease nipple	456	Rear grease valve closure plate

Nidec
All for dreams

LEROY-SOMERTM



Moteurs Leroy-Somer SAS
Headquarters: Boulevard Marcellin Leroy - CS 10015
16915 ANGOULÊME Cedex 9

Joint stock company with a capital of € 65,800,512
RCS Angoulême 338 567 258

www.leroy-somer.com